

NEW PRODUCTS

Trim Seal
Pages 18-20

Co-Extruded
Trim Seal
Page 21

Rubber Seal
Pages 30-36

Custom Rubber
Extrusion
Capabilities
Page 43

Our products use
3M Attachment Tapes

Decimal and Millimeter Equivalent

INCHES			DECIMALS	MILLIMETERS
1/8"	1/32"	1/64"	.01562	0.3968
		3/64"	.04687	1.19062
	1/16"	5/64"	.07812	1.98437
		3/32"	.09375	2.38125
		7/64"	.10937	2.77812
1/8"			.125	3.1780
3/16"	5/32"	9/64"	.14062	3.57187
		11/64"	.17187	4.36562
	7/32"	13/64"	.20312	5.15937
		15/64"	.23437	5.95312
	1/4"			.250
5/16"	9/32"	17/64"	.2656	6.7467
		19/64"	.2968	7.5405
	11/32"	21/64"	.3281	8.3342
		23/64"	.3593	9.1280
	3/8"			.375
7/16"	13/32"	25/64"	.3906	9.9217
		27/64"	.4220	10.3186
	15/32"	29/64"	.4531	11.5092
		31/64"	.4843	12.3029
	1/2"			.500
9/16"	17/32"	33/64"	.5156	13.0967
		35/64"	.5468	13.8904
	19/32"	37/64"	.5781	14.6841
		39/64"	.6093	15.4779
	5/8"			.625
11/16"	21/32"	41/64"	.6406	16.2716
		43/64"	.6718	17.0654
	23/32"	45/64"	.7031	17.8591
		47/64"	.7343	18.6528
	3/4"			.750
13/16"	25/32"	49/64"	.7656	19.4466
		51/64"	.7968	20.2403
	27/32"	53/64"	.8281	21.0341
		55/64"	.8593	21.8278
	7/8"			.875
15/16"	29/32"	57/64"	.8906	22.6215
		59/64"	.9218	23.4153
	31/32"	61/64"	.9531	24.2090
		63/64"	.9843	25.0028
	1"			1.000

TABLE OF CONTENTS





EDGE TRIMS

EDGE TRIM	4-9	
FIRE RETARDANT TRIM ...	10	
RUBBER LOK	11	
EDGE GUARD	12	
DECORATIVE TRIM	13	
RUBBER EDGE TRIM	14-15	
J-CLIP AND SEWABLE UPHOLSTERY TRIM.	16-17	

TRIM SEALS

TRIM SEAL	18-20	
CO-EXTRUDED TRIM SEAL..	21	
HATCH SEAL	22	
FLAP SEAL	23	

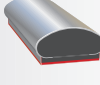
PLASTIC PROFILES

LIP GUARD	24	
DRIP RAIL/CARPET TRIM ..	25	
REDI-STIK	26	
PACKAGING OPTIONS	27	
RV APPLICATIONS.	28-29	

SEALS

RUBBER SEAL	30-36	
FENDER FLARE TRIM	34	
TUBING AND CORD	36	
O-RINGS	37	
LOCKING GASKET.	38-39	

TOOLS AND DESIGN ASSISTANCE

TOOLS AND ACCESSORIES	40-41
DESIGN-A-SEAL/ ADHESIVE OPTIONS	42
ADDITIONAL CAPABILITIES ..	43

EDGE TRIM

EDGE TRIMS

Edge Trim is a flexible PVC trim with individual internal metal clips and gripping tongues to provide a stronger grip.

Individual Metal Clips Retain a Permanent Grip

Strong Gripping Tongue

Many Applications

- Van Doors
- Truck Cabs
- Machinery Guards
- Boats
- Fiberglass
- Sheet Metal
- Forklifts
- Computer Cabinets
- Playground Equipment
- Golf Carts
- Tractor Cabs
- Helmets
- Riding Mowers



Check out our informative video at: www.edge-trim-install.info

OVER 40 YEARS OF



QUALITY & EXPERIENCE

FLEXIBLE AND EASY TO INSTALL!

1-888-874-6565
TRIM-LOK INC.
www.trimlok.com

EDGE TRIM



EDGE TRIMS

1 TRIM EDGE THICKNESS					2	3	4	
1/64"	1/32"	1/16"	3/32"	1/8"	Trim Series	Trim Color	Texture	Clip
0.016"	0.031"	0.063"	0.094"	0.125"	62 Series	White	Coarse=1 Sand=7	Alum.
						Black	Pebble=3 Sand=7	
See page 7 for "How to Order" Instructions.					75 Series	White	Coarse=1 Sand=7	Alum.
						Black	Pebble=3 Sand=7	
							Light Grey	
					750 Series	Black	Leather=2	Alum.

Product Specifications:

Recommended temperature range for general applications: -20°F. through +150°F.

Outer Coating Material:

Vinyl (PVC), Hardness: 85 Durometer (Shore A)

Internal Clip Material:

Aluminum or Steel

Flammability & Code Compliance:

Vinyl: FMVSS 302

FAA/FAR 23.853

UL 50

UL 844





FILE# MH49032

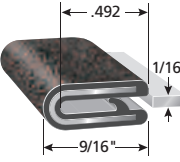
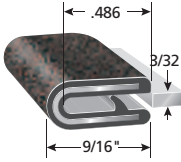
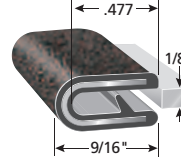
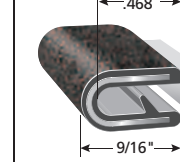
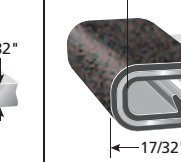
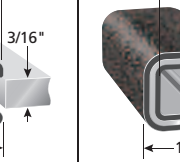
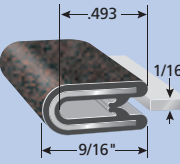
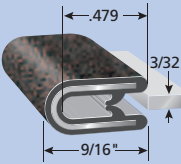
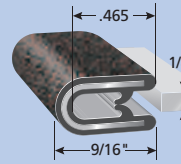
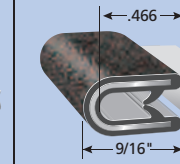
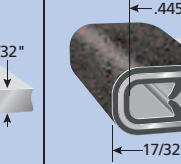
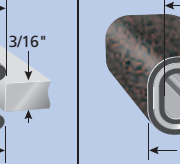
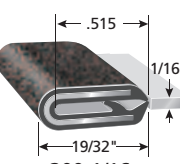
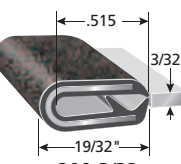
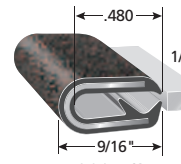
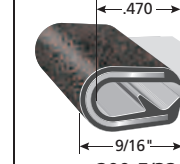
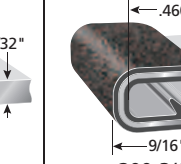
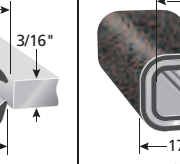

EDGE TRIM

1 TRIM EDGE THICKNESS

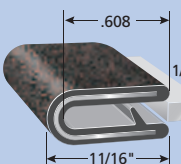
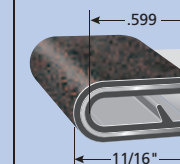
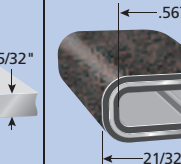
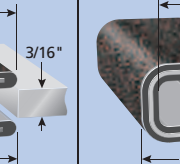
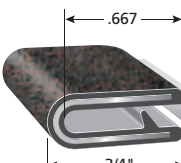
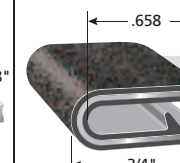
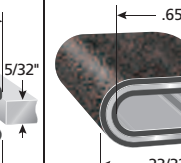
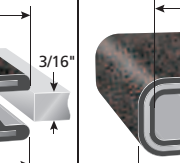
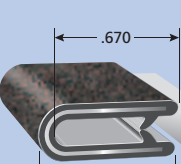
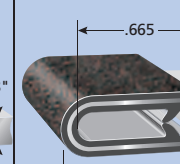
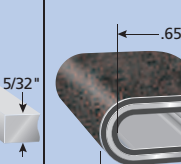
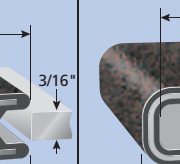
1/16"	3/32"	1/8"	5/32"	3/16"	1/4"
0.063"	0.094"	0.125"	0.156"	0.188"	0.250"
 <p>100-1/16</p>	 <p>100-3/32</p>	 <p>100-1/8</p>	 <p>100-5/32</p>	 <p>100-3/16</p>	 <p>100-1/4</p>
 <p>150-1/16</p>	 <p>150-3/32</p>	 <p>150-1/8</p>	 <p>150-5/32</p>	 <p>150-3/16</p>	 <p>150-1/4</p>
 <p>200-1/16</p>	 <p>200-3/32</p>	 <p>200-1/8</p>	 <p>200-5/32</p>	 <p>200-3/16</p>	 <p>200-1/4</p>
	 <p>1200-1/8</p>	 <p>1200-5/32</p>	 <p>1200-3/16</p>	 <p>1200-1/4</p>	
	 <p>1375-1/8</p>	 <p>1375-5/32</p>	 <p>1375-3/4</p>	 <p>1375-1/4</p>	
	 <p>1350-1/8</p>	 <p>1350-5/32</p>	 <p>1350-3/16</p>	 <p>1350-1/4</p>	

EDGE TRIMS

EDGE TRIM



HOW TO ORDER

1 Determine edge **THICKNESS** of your material. Use column 1.
 Measure thickness

2 Select **TRIM SERIES**. Determine how far trim is to be inserted. Use column 2.

3 Select available **COLOR**. Use column 3.

 B = Black W = White LG = Light Grey

4 Select type of **TEXTURE**. Use column 4.

 1 = Coarse 2 = Leather 3 = Pebble 7 = Sand

Determine **ORDER QUANTITY** in 250 foot increments. 5,000 feet minimum for custom colors.

Part Number Example **2** **3** **4** **1**
 750 **B** **2** X**1/32**



2	3	4	
Trim Series	Trim Color	Texture	Clip
100 Series	Black	Coarse=1 Leather=2 Pebble=3 Basketweave=5 Sand=7	Alum.
	Grey	Sand=7	
	White	Coarse=1 Basketweave=5 Sand=7	Steel (S)
	Tan	Coarse=1 Basketweave=5 Sand=7	
	Light Beige	Coarse=1 Pebble=3	
	Light Grey	Coarse=1	
	Silver	Coarse=1	
150 Series	Black	Leather=2 Basketweave=5 Sand=7	Alum.
	Light Grey	Leather=2	
	Silver	Coarse=1	
	White	Leather=2	
200 Series	Black	Pebble=3 Sand=7	Alum.
1200 Series	Black	Pebble=3 Sand=7	Steel (S)
1375 Series	Black	Pebble=3 Sand=7	Alum.
	Grey	Sand=7	
	Light Beige	Pebble=3	
	Light Grey	Pebble=3	
	Tan	Pebble=3	
	White	Pebble=3 Sand=7	
1350 Series	Black	Leather=2	Alum.
	White	Leather=2	

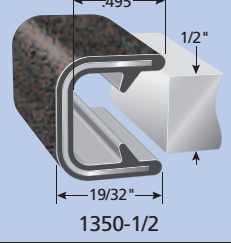
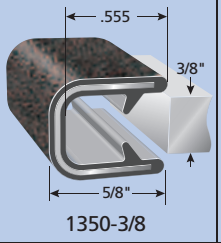
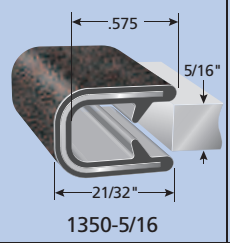
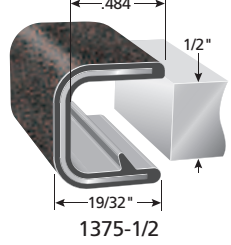
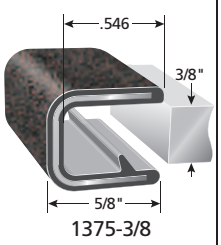
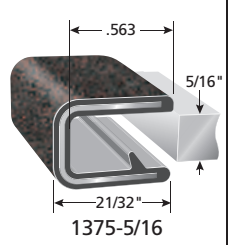

EDGE TRIM

EDGE TRIMS

1 TRIM EDGE THICKNESS

1/2"	5/8"	3/4"
0.500"	0.625"	0.750"

2 Trim Series	3 Trim Color	4 Texture	5 Clip
2000 Series	Jumbo Trim		Steel
	Black	Pebble=3	
	White	Pebble=3	

Jumbo Trim is a flexible PVC trim with individual internal metal clips and gripping tongue to provide a stronger grip.

HOW TO ORDER



- Determine edge **THICKNESS** of your material. Use column 1.

Measure thickness
- Select **TRIM SERIES**. Determine how far trim is to be inserted. Use column 2.

Leg Length Measure distance
- Select available **COLOR**. Use column 3.

B	W
B=Black	W=White
- Available **TEXTURE** is PEBBLE. Use column 4.

3 = Pebble
- Available **CLIP MATERIAL** is STEEL. Use column 5.

Part Number Example 2 5 3 4 1
 2000 S B 3 X1/2

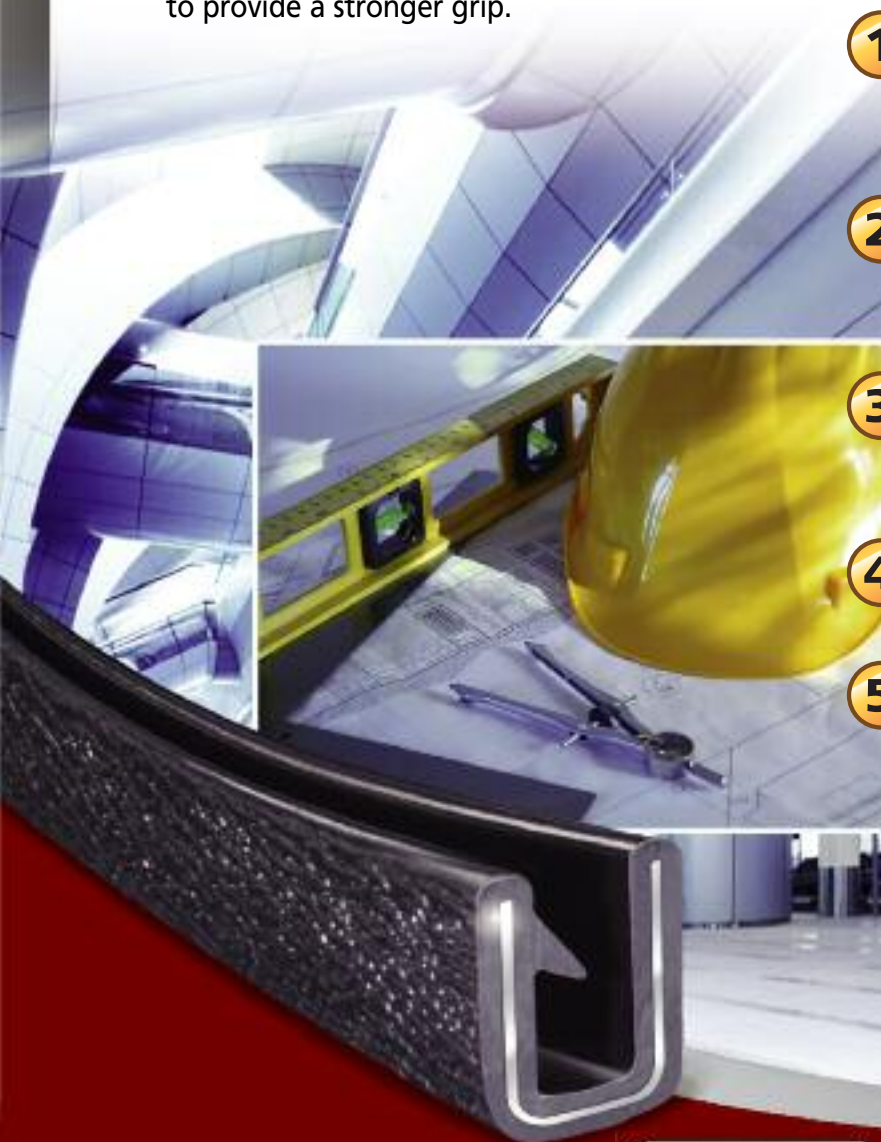

DESIGNED TO FIT A RANGE OF SIZES

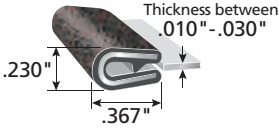
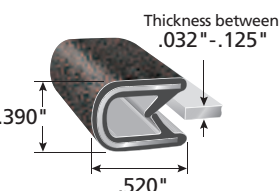
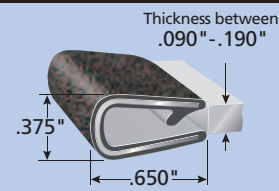
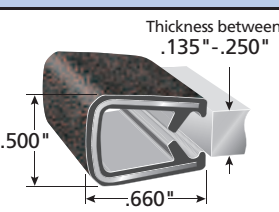
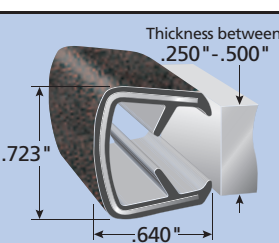

Trim Series	SIZE RANGE	COLOR	TEXTURE	CLIP	PART NO.
	FITS MATERIAL THICKNESSES FROM 0.010" TO 0.030"	Black	Pebble	Steel	1630SB3-1581
	FITS MATERIAL THICKNESSES FROM 0.010" TO 0.050"	Black	Pebble	Steel	1620SB3-341
		White	Pebble	Steel	1620SW3-342
	FITS MATERIAL THICKNESSES FROM 0.032" TO 0.125"	Black	Basket Weave	Steel	1600SB5-315
		Black	Pebble	Steel	1600SB3-317
				Aluminum	1600B3-317
		White	Pebble	Steel	1600SW3-1007
	FITS MATERIAL THICKNESSES FROM 0.085" TO 0.210"	Black	Basket Weave	Steel	1645SB5-336
		White	Pebble	Steel	1645SW3-337
		Black	Pebble	Steel	1645SB3-338
	FITS MATERIAL THICKNESSES FROM 0.090" TO 0.190"	White	Pebble	Steel	1640SW3-331
		Black	Pebble	Steel	1640SB3-708
	FITS MATERIAL THICKNESSES FROM 0.090" TO 0.190"			Steel	1650SB3-339
				Aluminum	1650B3-339
	FITS MATERIAL THICKNESSES FROM 0.135" TO 0.250"			Steel	1610SB3-343
				Aluminum	1610B3-343
		White	Pebble	Steel	1610SW3-344
	FITS MATERIAL THICKNESSES FROM 0.250" TO 0.500"	Black	Pebble	Steel	1660SB3-349
		White	Pebble	Steel	1660SW3-1628



FIRE RETARDANT TRIM

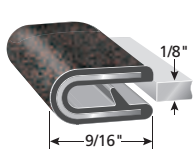
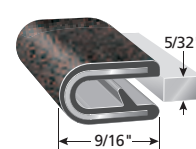
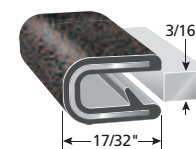
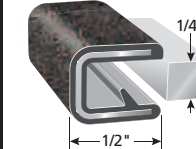
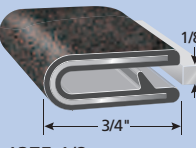
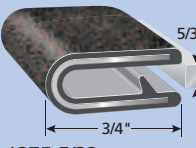

EDGE TRIMS

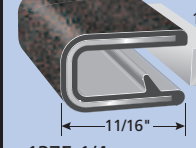
Fire Retardant Trim is a flexible trim with metal clips to provide a permanent grip. It is manufactured out of a thermoplastic Vulcanizate (TPV) material formulated to pass the National Fire Protection Agency (NFPA) standards. This material also complies with the UL 94HB flame requirements most commonly needed in electrical enclosure applications.

1 TRIM EDGE THICKNESS				2	3	4	
1/8"	5/32"	3/16"	1/4"	Trim Series	Trim Color	Texture	Clip
0.125"	0.156"	0.188"	0.250"	100 Series	Black	Pebble=3	Alum.
					White	Pebble=3	
				1375 Series	Black	Pebble=3	Alum.
100-1/8	100-5/32	100-3/16	100-1/4		White	Pebble=3	
1375-1/8	1375-5/32	1375-3/16	1375-1/4				

• UL94VO compliant vinyl available by special request only (reference Trim-lok Material #VY0117)

HOW TO ORDER

- Determine edge **THICKNESS** of your material. Use column 1.
Measure thickness 
- Select **TRIM SERIES**. Determine how far trim is to be inserted. Use column 2.
Leg Length  Measure distance 
- Select available **COLOR**. Using column 3.

B	W
---	---

B=Black W=White
- Select type of **TEXTURE**. Use column 4.

3 = Pebble

Part Number Example

100	B	3	TPRFR	X1/4
-----	---	---	-------	------



1-888-874-6565
TRIM-LOK® INC.
www.trimlok.com

RUBBER-LOK

Rubber-Lok simulates rubber and individual internal metal clips provide a secure grip.

Many Applications

- Boat Consoles
- ATV's
- Helmets
- Utility Trailers
- Truck Bodies
- Automobiles
- Sheet Metal Products

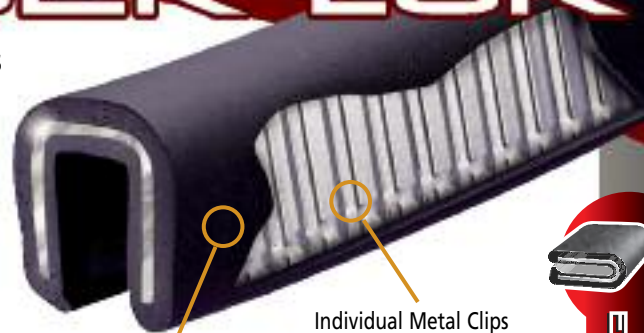

Black PVC Plastic that Offers a 'Rubber' Look and Feel

Individual Metal Clips Retain a Permanent Grip



RUBBER-LOK SERIES-THICKNESS

1/16"	3/32"	1/8"	3/16"	1/4"	
0.063	0.13	0.125	0.188	0.250	
1100 Series					
					Alum.
1100B7X1/16	1100B7X3/32	1100B7X1/8	1100B7X3/16	1100B7X1/4	
2200 Series					
					Steel
2200SB7X1/16	2200SB7X3/32	2200SB7X1/8	2200SB7X3/16	2200SB7X1/4	

Custom Materials:

Rubber-Lok can be ordered in special compounds based upon your specific application requirements.

Custom Colors:

Rubber-Lok can be ordered in custom colors to match your special needs. You can also highlight your trim with special decorative finishes.

Custom Profiles:

Special shapes or modifications to Rubber-Lok can be developed in order to meet your needs.

Custom Length:

Rubber-Lok can be ordered in specific cut lengths. Minimum quantities apply.

Product Specifications:

Recommended temperature range for general applications: -20°F. through +150°F.

Base Material:

Vinyl (PVC), Hardness: 78 Durometer (Shore A)

Internal Clip Material:

Aluminum or Steel



EDGE GUARD

EDGE TRIMS

Decorative Mylar

Clear Plastic

Hot Melt Adhesive

Edge-Guard is a pre-glued, flexible plastic trim with a mylar or clear cover. It gives a beautiful, finished appearance.

Many Applications

- Car Door Edges
- Furniture
- Vending Machines
- Running Boards
- Fender Flares

Product Specifications:

Recommended temperature range for general applications: -20°F. through +150°F.

Base Material:

Vinyl (PVC), Hardness: 97 Durometer (Shore A) Decorative Finish: Mylar

Adhesive:

Hot Melt Adhesive
Optional Butyl Adhesive Sealant



Edge-Guard®	Part No.	Size	Color
<p>5/16"</p> <p>Fits over edges up to 1/8"</p>	EGC5/16	5/16"	Chrome
	EGB5/16	5/16"	Black
	EGCL5/16	5/16"	Clear
<p>7/16"</p> <p>Fits over edges up to 3/16"</p>	EGC7/16	7/16"	Chrome
	EGB7/16	7/16"	Black

DECORATIVE TRIM

Decorative Trim is a flexible PVC trim with chrome and finishes.

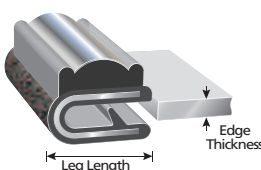
1 Finish	2 Trim Series	3 Trim Color	4 Texture	Profile (Approx. full size)	5 Edge Thickness	Leg Length	Internal Clip	Part Number Example
8=Chrome	100 Series	White	1=Coarse Pebble 7=Sand		1/16"	9/16"	Alum.	8100B3X1/8
		Black	3=Pebble 7=Sand		3/32"	9/16"		
			1=Coarse Pebble 7=Sand		1/8"	9/16"		
					5/32"	9/16"		
					3/16"	17/32"		
					1/4"	1/2"		

Decorative Trim Seal

is a flexible PVC trim with decorative finishes. It can be supplied with or without an EPDM sponge rubber bulb to provide a secure seal for a variety of applications.

Product Specifications:

Recommended temperature range for general applications: -20°F through +150°F.

Outer Coating Material:

Vinyl (PVC), Hardness: 85 Durometer (Shore A)

Internal Clip Material:

Aluminum or Steel

Flammability & Code Compliance:

Vinyl: FMVSS 302
FAA/FAR 23.853
UL 50

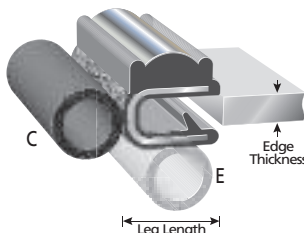
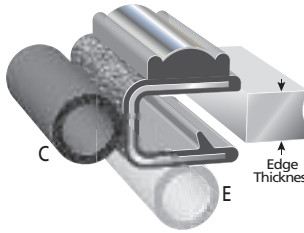
1 Finish	3 Trim Series	4 Trim Color	5 Texture	Profile	6 Edge Thickness	Leg Length	7 Bulb Location	Internal Clip	Part Number Example
8=Chrome	100 Series	White	1=Coarse Pebble 7=Sand		1/16"	9/16"	C	Alum.	1 Finish 2 Bulb Size 3 Trim Series 83100B3X1/8C 4 Trim Color 5 Texture 6 Edge Thickness 7 Bulb Location
		Black	3=Pebble 7=Sand		3/32"	9/16"			
		Tan	1=Coarse Pebble 7=Sand		1/8"	9/16"			
					5/32"	9/16"			
					3/16"	17/32"			
					1/4"	1/2"			
8=Chrome	375 Series	White	3=Pebble 7=Sand		1/8"	3/4"	C	Alum.	See page 18 for "How to Order" Instructions.
		Black	3=Pebble 7=Sand		5/32"	3/4"			
		Tan	3=Pebble 7=Sand		1/4"	11/16"			
					5/16"	21/32"			
					3/8"	5/8"			
					1/2"	19/32"			

2 Bulb Sizes Available

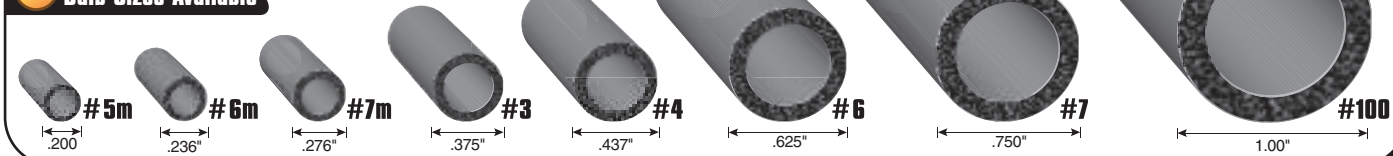

These parts may require minimum orders and longer leadtimes.

RUBBER EDGE TRIM

EDGE TRIMS



Very Flexible to Fit Tight Radius

Pre-Applied Butyl Sealant or Hot-Melt Adhesive

Rubber Edge Trims are available in either **EPDM** or **Neoprene**, these two different materials are designed to fit your application perfectly.

Neoprene is a well proven proprietary blend that weathers well, has very good resistance to abrasion, flex cracking, alkalis, and acids and is best used in applications where flame resistance is a requirement. This material has moderate resistance to oils and gasoline. Neoprene is generally considered an excellent all-purpose material with a solid balance of properties and few limitations. However, expect poor resistance to aromatic and oxygenated solvents and limited flexibility at low temperatures. Hardness:70 Durometer (Shore A) Service temperature ranges from -40°F to 225°F.

EPDM has excellent performance characteristics. EPDM (Ethylene-Propylene-Diene-Monomer) is best known for its excellent ozone, weathering, and aging resistance. It also has excellent water and steam resistance, maintains its flexibility at low temperatures, features excellent resistance to alkalis, acids, and oxygenated solvents, and is very color stable. It is not recommended for resistance to oil, gasoline, and hydrocarbon solvents. EPDM is found in a wide range of applications and is excellent for use outdoors.

Hardness:70 Durometer (Shore A)
Service temperature ranges from -40°F to 225°F.

Butyl Sealant can be ordered pre-applied and provides excellent sealing characteristic with good heat performance.

Service temperature ranges from -20°F to 158°F.

Hot Melt Adhesive can be ordered pre-applied and to provide a stronger grip with good heat performance.

Service temperature ranges from -20°F to 158°F.

Cut to Length All Rubber Edge Trims can be ordered in pre-cut lengths and can be individually packed. Minimum orders apply

RUBBER EDGE TRIM-THICKNESS

1/32"	1/16"	1/16"	1/8"
0.032	0.063	0.063	0.125
<p>X1001</p>	<p>X1002</p>	<p>X2017</p>	<p>X1003</p>
<p>X1010</p>	<p>X1011</p>		<p>X1012</p>
<p>X2001</p>	<p>X2002</p>	<p>X2073</p>	<p>X2003</p>
<p>X2012</p>	<p>X2013</p>	<p>X2008</p>	<p>X2014</p>
<p>X2059</p>	<p>X2010</p>		<p>X2102</p>
<p>X1466</p>	<p>X2009</p>		<p>X2006</p>

RUBBER EDGE TRIM

EDGE TRIMS

3/16" 0.188	1/4" 0.250	5/16" 0.313	3/8" 0.375
<p>X1004</p>	<p>X1005</p>	<p>X1006</p>	<p>X1007</p>
<p>X1013</p>	<p>X1014</p>	<p>X1015</p>	<p>X1016</p>
	1/8 0.125	1/2" 0.500	3/4" 0.750
<p>X2004</p>	<p>X2060</p>	<p>X1018</p>	<p>X2007</p>
<p>X2015</p>			
<p>X2011</p>			

HOW TO ORDER

Neoprene Part# Example

X1001 WG

WG=with glue
WB=with pre-applied
butyl sealant

Rubber Edge Trim profile

EPDM Part# Example

X1001 E WG

WG=with glue
WB=with pre-applied
butyl sealant
E=EPDM

Rubber Edge Trim profile

J-CLIP AND SEWABLE UPHOLSTERY TRIM



EDGE TRIMS

Upholstery Trims and J-Clips

are manufactured out of a sewable non-break material. Fabric can be sewn to these parts and used to keep the material tight to the seat frame once in place.

UPHOLSTERY TRIM

Product Specifications:

Recommended temperature range for general applications: -20°F. through +150°F.

Outer Coating Material:

Vinyl (PVC), Non-break. Hardness: 85 Durometer (Shore A)

Internal Clip Material: Aluminum

Profile	Part No.	Color
	529B3X1/8	Black
	529CC036-3X1/8	Gray
	529CC037-3X1/8	Taupe

Custom colors available minimums apply



Upholstery Trim is sewn to leather seat cover to attach to seat frame

J-CLIPS

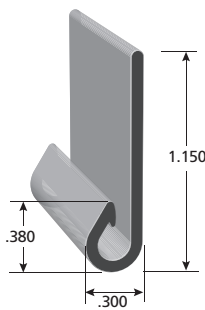

I11026

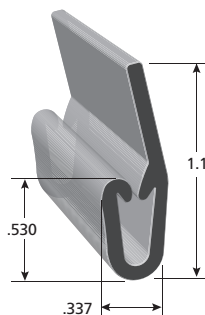

I11038

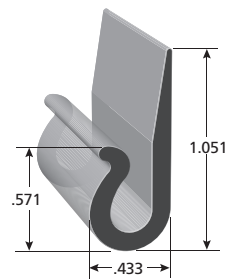

I11023

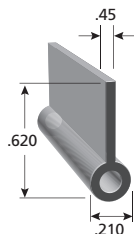

I11053

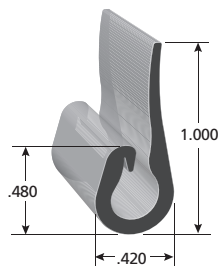

I11109

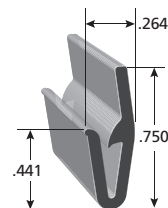

I11102

Product Specifications:

Recommended temperature range for general applications: -20°F. through +150°F.

Material:

Polypropelyene, Non-break. Hardness: 90 Durometer (Shore A)

J-CLIP AND SEWABLE UPHOLSTERY TRIM

J-CLIPS

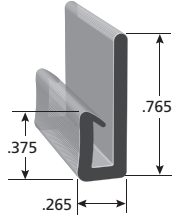

I11114

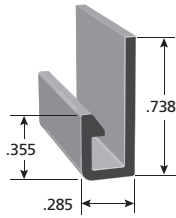

I11099

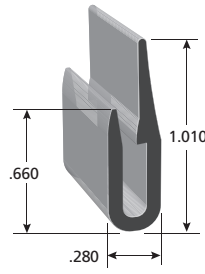

I11107

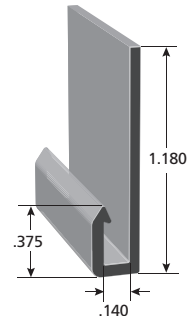

I11039

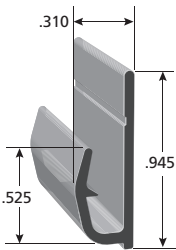

I11103

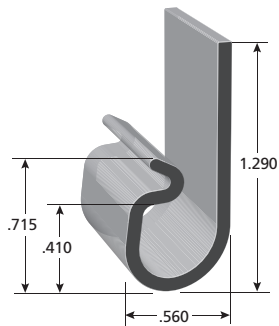

I11108

I11059
Matching
Sewable
Insert

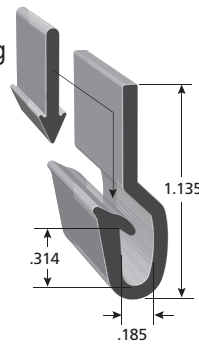

I11060

I11071
Matching
Sewable
Insert

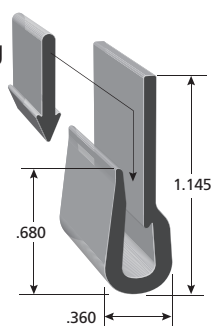

I11072

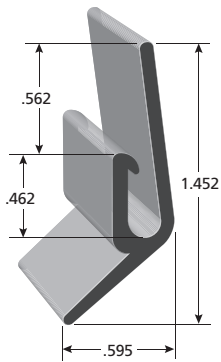

I11105

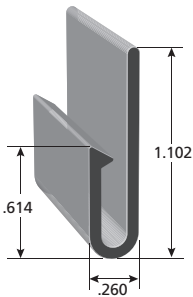

I11024



TRIM SEAL

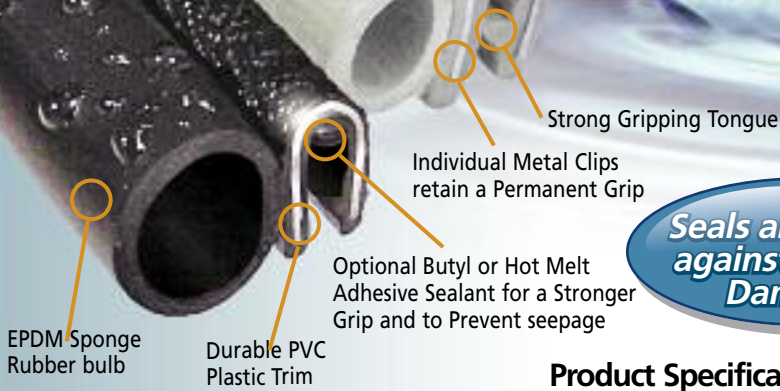

Seals and Protects against Weather Damage!

Trim Seal is a flexible PVC Trim with a sponge rubber bulb seal attached to provide a secure seal for a variety of applications.

Check out our informative video at: www.trim-seal-install.info



Product Specifications:
 Recommended temperature range for general applications: -20°F through +150°F.
Outer Coating Material:
 Vinyl (PVC), Hardness: 85 Durometer (Shore A)

Internal Clip Material:
 Aluminum or Steel
Flammability & Code Compliance:
 Vinyl: FMVSS 302
 FAA/FAR 23.853
 UL 50



FILE# MH49032



Many Applications

- Boat Hatch Seals
- RV Compartments Door Seals
- Tonneau Cover Seals
- Tool Box Seals
- Many More

HOW TO ORDER

Determine **BULB COLOR**

OW OW = Offwhite B Black = No callout necessary

Determine **BULB SIZE** based on closed distance between door and jam.
 1.5 x Closed dimension = **BULB SIZE** needed.
 (Example: Closed dimension is .50 then 1.50 x .50 = .75 Bulb Dia.)

1

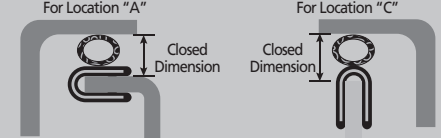

Select **TRIM SERIES**

Determine how far trim is to be inserted.

2

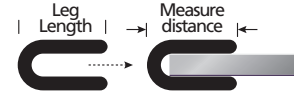

Determine **TRIM COLOR** to best suit application

3

B	W	T	LB	LG
B = Black	W = White	T = Tan	LB = Light Biege	LG = Light Grey

Determine **TEXTURE** to best suit application

4

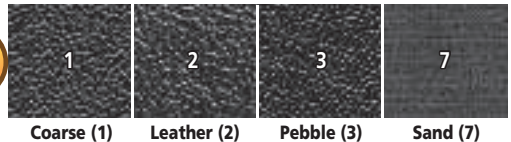

5

Determine edge **THICKNESS**

Select **BULB LOCATION** best to suit.

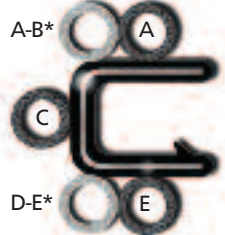

6











Typical Applications



* A-B or D-E non-standard location, special order, non-returnable

Part Number Example

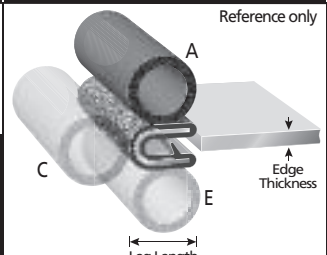
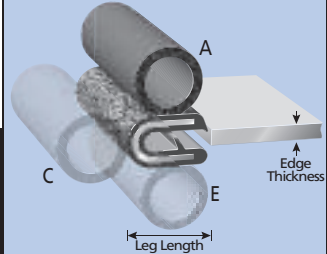
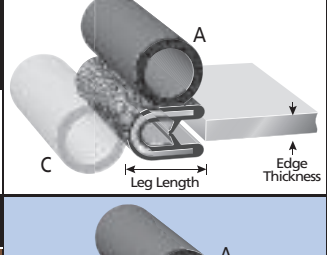
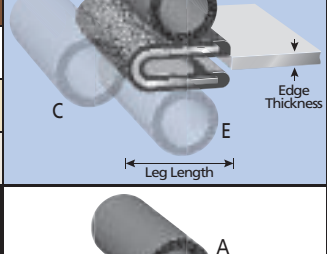
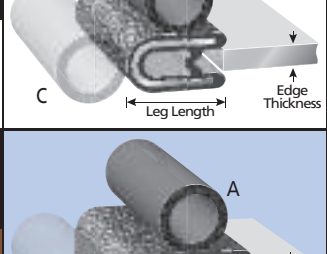
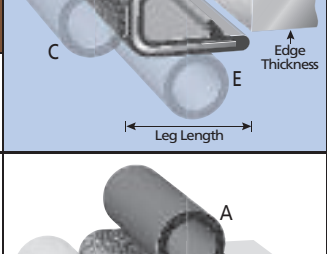
OW **3** **100** **B** **3** **X1/8** **A**

1 Bulb Sizes Available	2 Trim Series	3 Trim Color	4 Texture	Profile (Approx. full size)	5 Edge Thickness	Leg Length	6 Bulb Location	Internal Clip	Part Number Example
 #5m  #6m  #7m  #3  #4  #6  #7  #100	062 Series	White	1=Coarse Pebble 7=Sand		1/64"	3/8"	A	Alum.	1 Bulb Size 2 Trim Series 3 Trim Color 7m062B3X1/64A Texture 4 Edge Thickness 5 Bulb Location 6
		Black	3=Pebble 7=Sand		1/32"	3/8"	C		
	075 Series	White	1=Coarse Pebble 7=Sand		1/32"	7/16"	A	Alum.	4075B3X1/32A
		Black	3=Pebble 7=Sand		1/16"	7/16"	C		
	750 Series	Black	2=Leather		1/32"	7/16"	A	Alum.	3750B2X1/16A
		White	1=Coarse Pebble 7=Sand		1/16"	7/16"	C		
	100 Series	Black	3=Pebble 7=Sand		1/32"	37/62"	A	Alum.	6100B3X1/8EWB
		Tan	1=Coarse Pebble 7=Sand		1/16"	9/16"			
		White	2=Leather		3/32"	9/16"		C	
		Light Biege	3=Pebble		1/8"	9/16"		E	
		Light Grey	1=Coarse Pebble		5/32"	9/16"		E	
	150 Series	Black	2=Leather		1/32"	37/62"	A	Alum.	7150B2X5/32A
		White	2=Leather		1/16"	9/16"			
	1375 Series	Black	3=Pebble 7=Sand		1/8"	3/4"	A	Alum.	4375B3X3/8C 1 Bulb Size 2 Trim Series 3 Trim Color 4 375 B 3 X 3/8 C W B Texture 4 Edge Thickness 5 Bulb Location 6 Butyl Adhesive
		Tan	3=Pebble		5/32"	3/4"			
		White	3=Pebble 7=Sand		3/16"	23/32"			
	1350 Series	White	2=Leather		1/4"	11/16"	A	Alum.	4350B2X1/2A
		Black	2=Leather		5/16"	21/32"			
					3/8"	5/8"			
					1/2"	19/32"			



TRIM SEAL

1 Bulb Size	2 Trim Series	3 Trim Color	4 Texture	Jumbo Trim Seal Profile (Approx. full size)	5 Edge Thickness	Leg (Fixed size)	6 Bulb Location	Internal Clip	Part Number Example		
#5m	2000 Series	White	3=Pebble		1/2"	1"	A	Steel	<p>1 Bulb Size 2 Trim Series 3 Trim Color 7 2000 SB 3 X 3/4 A Texture 4 Edge Thickness 5 Bulb Location 6</p> <p>See page 19 for bulb size illustrations</p>		
#6m					5/8"	15/16"	C				
#7m					3/4"	7/8"	E				
#3		Black	3=Pebble		#4	#6	#7			#100	
			Tan		3=Pebble						

Additional Trim Seal

Combine any of our stock Rubber Seals with our Regular Trim to achieve the perfect Trim-Seal combination for your application. (Longer lead times and minimums may apply.)

<p>103B375B3X3/16E</p>	<p>113B100B3X1/8E</p>	<p>1333B100B3X1/8E</p>	<p>3B150B2X1/8A</p>
<p>1B150B2X1/8C</p>	<p>105B100B3X1/8A</p>	<p>109B375B3X3/16E</p>	<p>202B100B3X1/8E</p>
<p>135B375B3X3/16E</p>	<p>See page 18 for "How to Order" Instructions.</p> <p>Check with your Trim-Lok sales representative for additional bulb size options.</p>		

CO-EXTRUDED TRIM SEAL

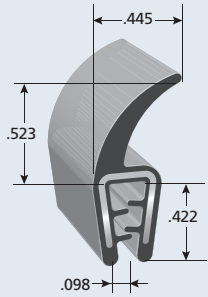

DDA1501
EPDM Dense

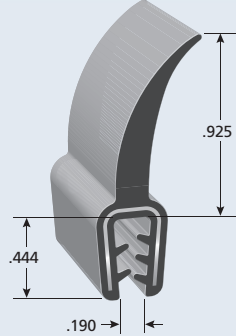

DD1201
EPDM Dense

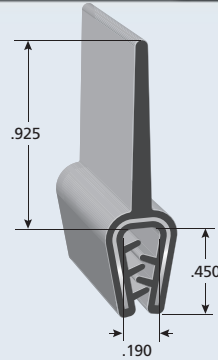

DD6112
EPDM Dense

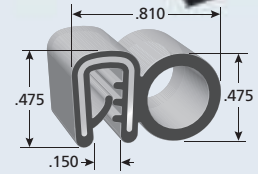

DD6138
EPDM Dense

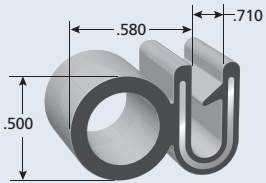

DD6114
EPDM Dense

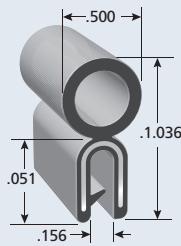

DD6131
EPDM Dense

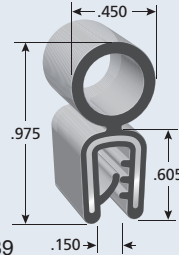

DD6139
EPDM Dense

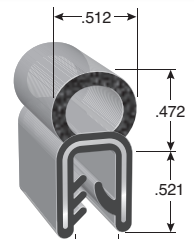

DD1013

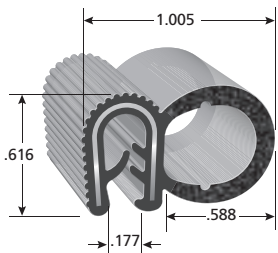

DDA3229

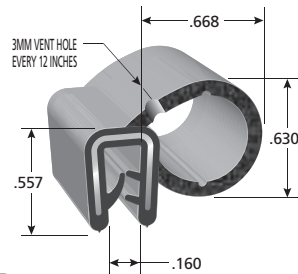

DD1004

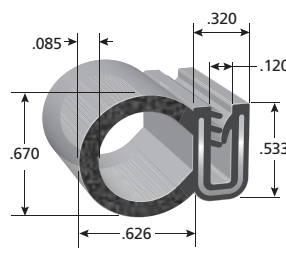

DD6100

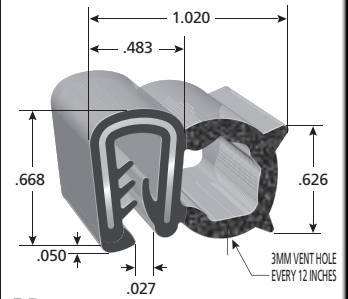

DD6118

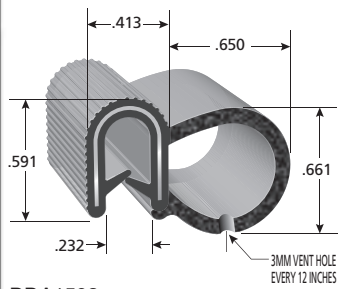

DDA1503

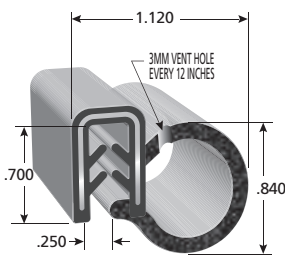

DD6130

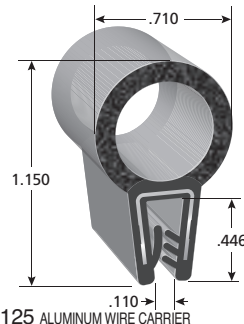

DD6125 ALUMINUM WIRE CARRIER
DD1614 ALUMINUM CLIP CARRIER

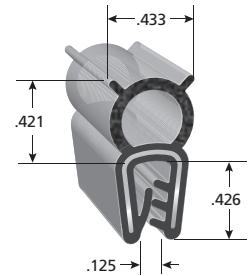

DDA2513

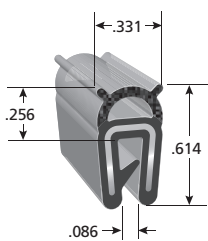

DDA2518

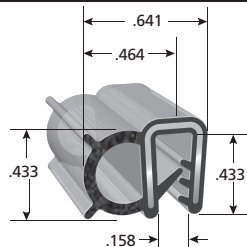

DDA1549

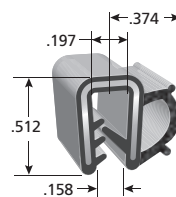

DD6123

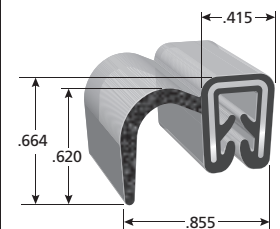

DD6126



HATCH SEAL

Resists kinks in a radiused corner



Durable PVC Plastic Trim

EPDM Sponge Rubber Bulb

Tear Resistant

Individual Metal Clips Retain a Permanent Grip

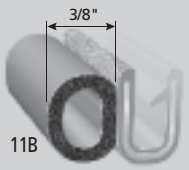
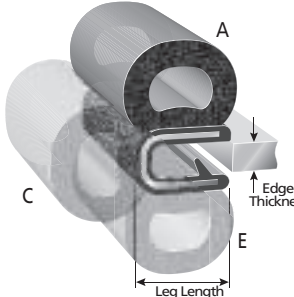
Hatch Seal is a specially formulated compound rubber that provides a watertight seal and prevents leaks.
Service Temp: -20°F. through +158°F.

1 Bulb Size	2 Trim Series	3 Trim Color	4 Texture	Profile (Approx. full size)	5 Edge Thickness	Leg Length	6 Bulb Location	Example Part Number
 11B	100 Series	Black	3=Pebble 7=Sand	 Not to scale	1/16"	9/16"	A	1 Bulb Size 2 Trim Series 3 Trim Color 12B 100 B 7 X 3/16 A
 12B					3/32"	9/16"		
					1/4"	1/2"	E	Edge Thickness 5
					3/16"	17/32"	C	Bulb Location 6
					1/4"	1/2"		

TRIM SEALS

FOR A WATER TIGHT SEAL!



Typical Application

- Greater tear strength
- Protects against weathering
- Wide range of sizes to fit precisely
- Reduces noise and vibrations
- Optional butyl adhesive sealant for a stronger grip and to prevent seepage into storage compartment

1-888-874-6565
TRIM-LOK INC.
 www.trimlok.com

FLAP SEAL

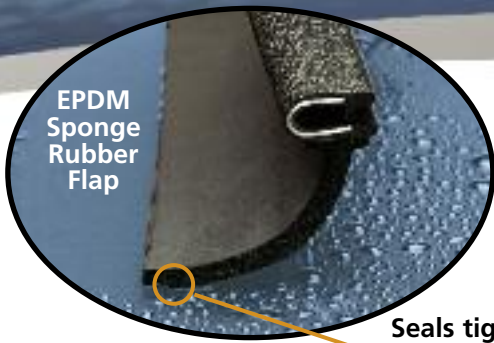

Seals tight to
protect against
weather damage

Durable PVC Plastic Trim

Strong Gripping
Tongue

Individual Metal
Clips retain a
Permanent Grip

Exceptional
Bond Surface

EPDM Sponge
Rubber Flap

Flap Seal is a flexible PVC trim with a EPDM sponge rubber flap attached to provide a secure seal in a variety of dynamic applications.
Service Temp: -20°F. through +158°F.

1 Flap Length	2 Trim Series	3 Trim Color	4 Texture	Profile (Approx. full size)	5 Edge Thickness	Leg Length	6 Flap Location	Internal Clip	Example Part Number
5B=1"	100 Series	White	1=Coarse Pebble 7=Sand	<p>Reference only</p> <p>C Location fits 1/4" Trim only</p>	1/16"	9/16"	A	Alum. Steel	1 Flap Length 2 Trim Series 3 Trim Color 6B100B3X18A Texture 4 Edge Thickness 5 Flap Location 6
6B=1.75"					3/32"	9/16"			
7B=3"					1/8"	9/16"			
8B=1.75"					5/32"	9/16"			
5B=1"	150 Series	Black	3=Pebble 7=Sand	<p>C Location fits 1/4" Trim only</p>	3/16"	17/32"	E		
8B=1.75"					1/4"	1/2"			
5B=1"	1350 Series	White	3=Pebble 7=Sand	<p>C Location fits 1/4" and above Trim only</p>	1/8"	3/4"	A	Alum.	
6B=1.75"					5/32"	3/4"			
7B=3"					1/4"	23/32"			
8B=1.75"					5/16"	21/32"			
5B=1"	1375 Series	Black	3=Pebble 7=Sand	<p>C Location fits 1/4" and above Trim only</p>	3/8"	5/8"	E		
8B=1.75"					1/2"	19/32"			
5B=1"					1/4"	11/16"			
					5/16"	21/32"	C		
					3/8"	5/8"			
					1/2"	19/32"			

HOW TO ORDER

- Determine the **FLAP LENGTH** using column. . . . 1
- Determine the **TRIM SERIES #** using column. . . . 2
- Determine the **TRIM COLOR** using column. . . . 3
- Determine the **TRIM TEXTURE** using column. . . . 4
- Determine the **EDGE THICKNESS** using column. . . . 5
- Determine the **FLAP LOCATION** using column. . . . 6

Typical Applications

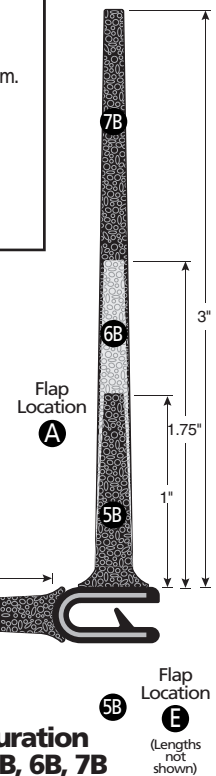

To order flaps separately See page 35

LIP GUARD



Lip Guard is a plastic trim with a mylar cover and peel-off tape. This pliable trim comes in chrome, gold, and black and has the durability to meet interior or exterior design requirements. Paintable Lip-Guard can be painted to specific color using vinyl base paint.

Many Applications

- Running Boards
- Spas
- Unfinished Edges
- Camper Shells
- Truck Bed Covers
- Fender Flares
- Car Fenders

Product Specifications:

Recommended temperature range for general applications: -20°F. through +150°F.

Base Material:

Vinyl (PVC), Hardness: 97 Durometer (Shore A)



Decorative Finish:

Mylar

Adhesive:

3M™ Acrylic Foam Tape with peel-off liner

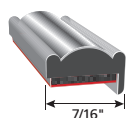
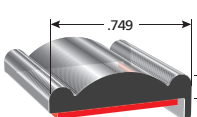

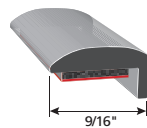
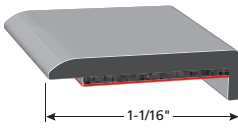
Lip Guard®	Part No.	Roll Size	Size	Color
	LGC	500 ft	7/16"	Chrome
	LGB	500 ft	7/16"	Black
	LGB3/4	500 ft	3/4"	Black
Paintable Lip Guard	Part No.	Roll Size	Size	Color
	PLGB	500 ft	9/16"	Black
	JLGB	250 ft	1 1/16"	Black

Paintable Lip Guard is...

- Designed to replace the aluminum trim on fiberglass shells
- Can be painted with vinyl based paint
- Designed for camper shells and running boards
 - Pliable and durable to meet exterior design requirements

PLASTIC PROFILES

DRIP RAIL

Drip Rail is a flexible plastic peel 'n stick rain gutter that eliminates time consuming installation of aluminum rain gutters.

- Easy to install with **3M™ Acrylic Automotive Grade Foam Tape**.
- Bonds above windows on your truck, car, RV or boat to channel off water
- Eliminate streaks from dew and drizzle
- Control water runoff.

E-Z Peel 'n Stick Rain Gutter with **3M™ Acrylic Foam Tape**

Durable PVC Plastic

Special 'J' design to Channel-off Rain

Product Specifications:

Recommended temperature range for general applications: -20°F. through +150°F

Adhesive:

3M™ Acrylic Foam Tape with peel-off liner

Base Material:

Vinyl (PVC), Hardness: 85 Durometer (Shore A)

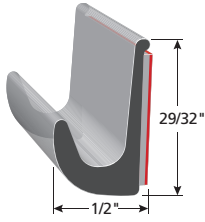
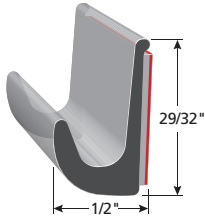
Profile	Part No.	Color
	DRB	Black
	DRW	White

Sold in 50 or 250 foot increments



Check out our informative video at: www.drip-rail-install.info

Custom sizes and colors are available on request. Minimums apply.

CARPET TRIM

Carpet Trim is a flexible PVC trim with a peel and stick carpet edge to prevent carpet frays while providing a finished look.

Product Specifications:

Recommended temperature range for general applications: -20°F. through +150°F.

Base Material:

Vinyl (PVC), Hardness: 93 Durometer (Shore A)

Finish:

Gloss Black

Adhesive:

3M™ Acrylic Automotive Grade Foam Tape with peel-off liner

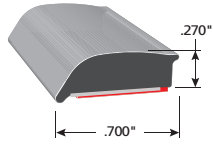
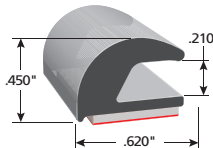
Carpet Trim	Part No.	Size	Color
	CP1043	.70	Black
	I11134	.620	Black

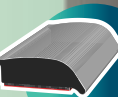

PLASTIC PROFILES

REDI-STICK



Decorative Mylar

Durable PVC Plastic

3M™ Acrylic Foam Tape
Peel-off Liner

Redi-Stik is a flexible plastic trim with a decorative mylar cover. This versatile trim gives an elegant, polished appearance. It comes in two sizes and various colors.

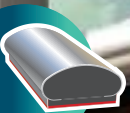

PLASTIC PROFILES

Product Specifications:

Recommended temperature range for general applications: -20°F. through +150°F.

Base Material:

Vinyl (PVC), Hardness: 97 Durometer (Shore A)

Decorative Finish:

Mylar

Adhesive:

3M™ Acrylic Foam Tape with peel-off liner

Redi-Stik®	Part No.	Roll Size	Size	Color
	RSC5/16 RSB5/16	500 ft 500 ft	5/16"	Chrome Black
	RSC7/16 RSB7/16	500 ft 500 ft	7/16"	Chrome Black
	CP1154	250 ft	1 1/4"	Chrome
	CP1155	250 ft	1 1/4"	Black

Minimums may apply.

PACKAGING OPTIONS

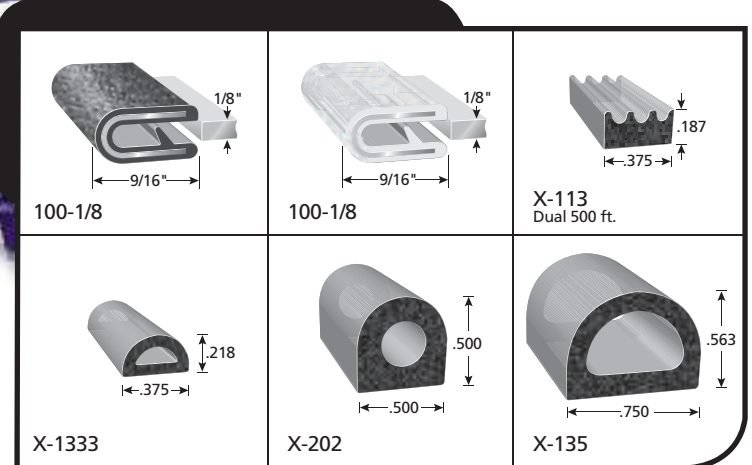

OPTION 1

Option One These boxes are designed to allow the customer to feel the part while still preserving the integrity of the packaging. This option also has a foldable tab allowing them to be hung on a peg or stacked on a shelf.

- | | | |
|-----------------------|----------------------------|----------|
| AM100B3X1/8-25 | 25 packs of black 100-1/8 | (25 ft.) |
| AM100W3X1/8-25 | 25 packs of white 100-1/8 | (25 ft.) |
| AMX113HT-50 | 25 packs of black X-113HT | (50 ft.) |
| AMX202HT-25 | 25 packs of black X-202HT | (25 ft.) |
| AMX1333HT-50 | 25 packs of black X-1333HT | (50 ft.) |
| AMX135HT-10 | 25 packs of black X-135HT | (10 ft.) |

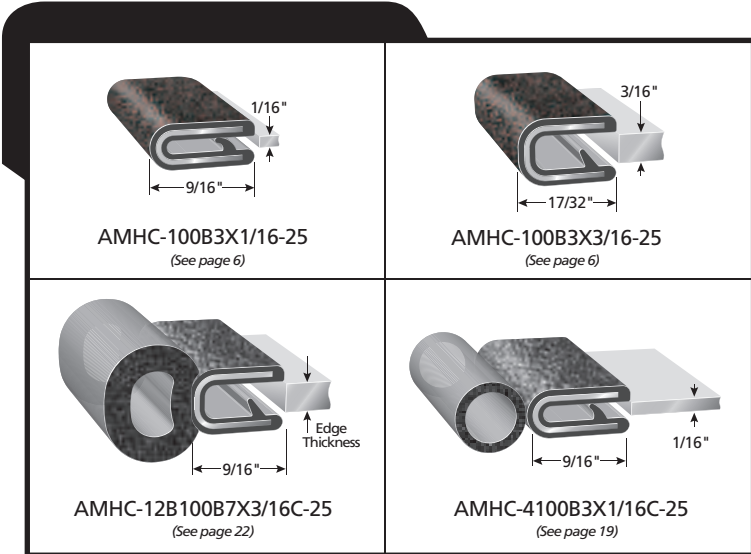

Minimums and lead times may apply.

OPTION 2

Option Two This packaging option is a hangable poly bag that captures and protects the parts. This option is also available in for those customers that need a private label attached.

Hanging Polybag Option



PLASTIC PROFILES

RV APPLICATIONS

RV PARTS Trim-Lok has been serving the RV industry at the OEM level as well as the replacement part level for over 40 years.

This page has been created to quickly and easily identify some of the most frequently used parts and some of their applications.

Each part has minimum quantities required at time of order.

VENT SEALS

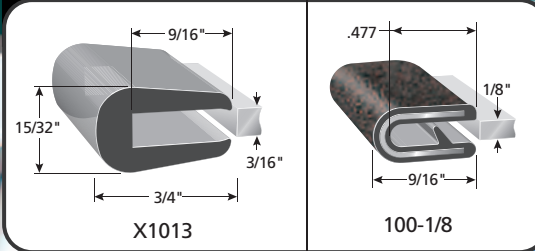

ENTRY DOOR SEALS

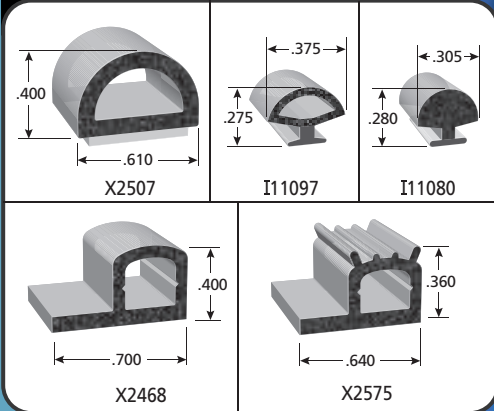

FENDER TRIM

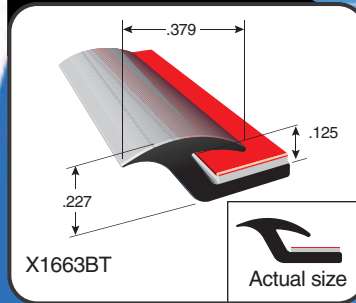

SLIDE OUT FLAPS

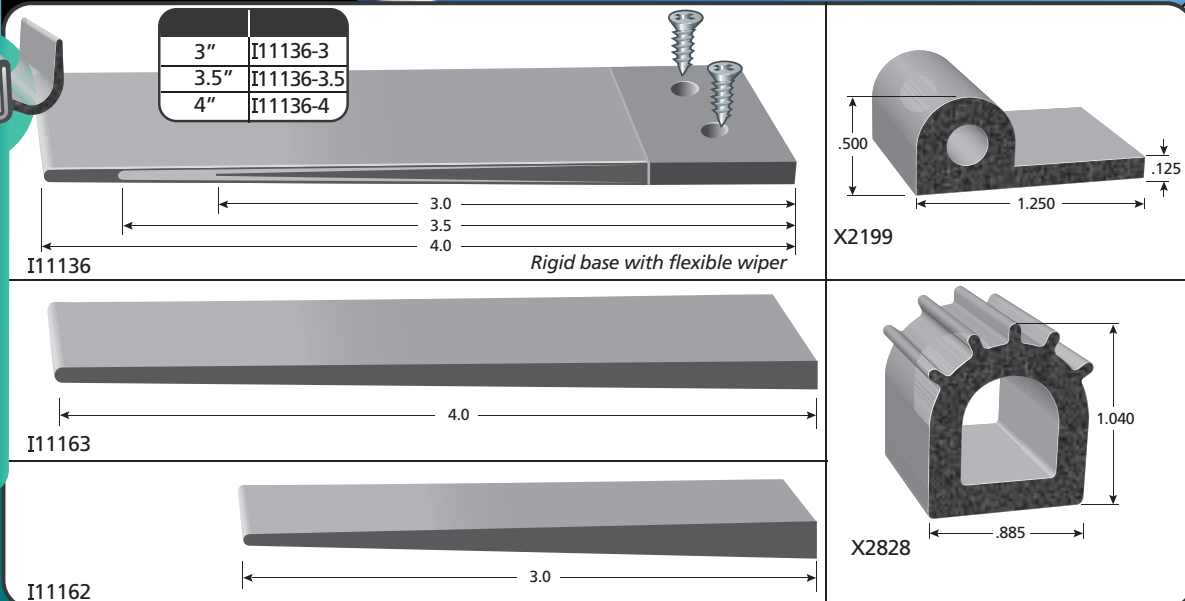



SEE SHOP ORDER FOR COLOR, AND FINISH INFORMATION.

PROPRIETARY NOTICE
 THIS DOCUMENT CONTAINS PROPRIETARY INFORMATION AND ALL INFORMATION HEREON IS THE PROPERTY OF TRIM-LOK, INC. POSSESSION OF THIS DOCUMENT DOES NOT CONSTITUTE ANY RIGHT TO TRANSMIT SUCH INFORMATION OR USE, SELL OR MANUFACTURE FROM SUCH INFORMATION, AND NO REPRODUCTION OR PUBLICATION OF THIS DOCUMENT, IN WHOLE OR IN PART, SHALL BE MADE WITHOUT WRITTEN AUTHORIZATION FROM TRIM-LOK, INC.

RV APPLICATIONS

RV APPLICATIONS

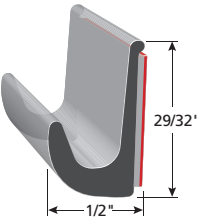
DRIP RAIL

Profile	Part No.	Color
	DRB	Black
	DRW	White

Sold in 50 or 250 foot increments

SCREW CAP COVERS

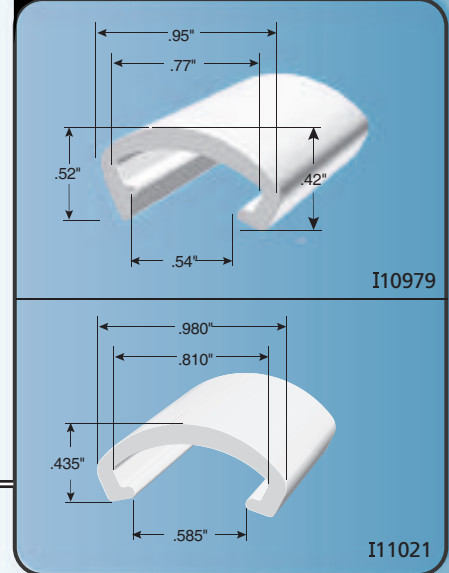

WINDOW SEALS

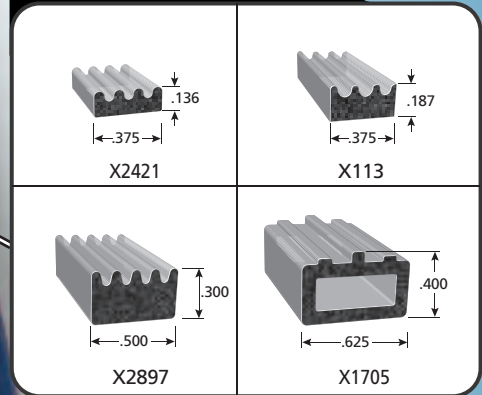

BAGGAGE DOOR TRIM SEALS

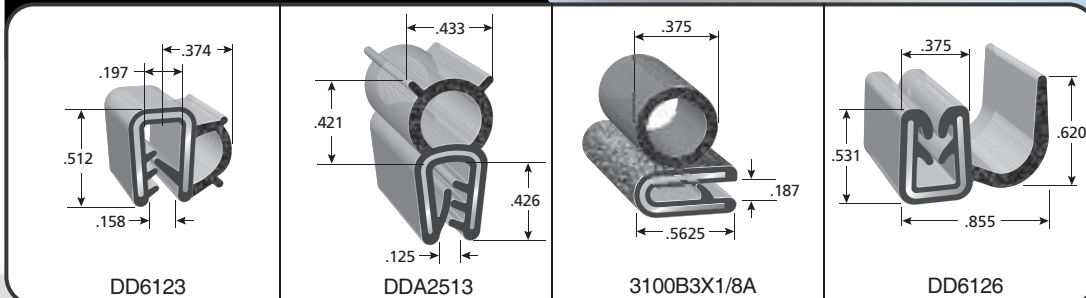

RUBBER SEAL



SEALS

Ozone Resistant
EPDM Rubber

Pressure Sensitive
Adhesive (PSA) Tape
with Peel-Off Liner

For the Best Tape Fit
See Page #42

FOR A WATER
TIGHT SEAL!

Rubber Seals come in a variety of specially designed shapes, made from custom formulated E.P.D.M. sponge rubber compound.

RUBBER SEAL DISCLAIMER: Due to a constant effort to update our Rubber Seal products, specifications are subject to change without notice and without incurring obligation. Because we cannot anticipate or control the many different conditions which this information and our products may be used, Trim-lok does not guarantee the applicability, accuracy or the suitability of a product in any given situation. Users should conduct their own tests to determine the suitability of each product for a particular application. The products described here are sold without warranty either expressed or implied and the buyer assumes all responsibility for loss or damage arising from the handling and use of our products.

CLEANING AND APPLICATION INSTRUCTIONS

Regardless of bonding surface, it must be clean and free of surface contaminant such as oil, grease, mold release and dirt. Most bonding failures are due to improperly cleaned surfaces. Prior to applying any adhesive, clean surface with 50/50 denatured alcohol and water solution.



Product Specifications:

Recommended temperature range for general applications:
-20°F. through +150°F.
Sponge Rubber (EPDM)

Application:

For optimum performance -
25% - 50% maximum compression recommended.

Resistance Ratings:

Excellent resistance to water absorption, ozone, sunlight aging, low temperature, and compression set.

Flammability and Code Compliance:

FMVSS 302
UL 50



1-888-874-6565

TRIM-LOK INC.
www.trimlok.com

RUBBER SEAL

Part Number Example

Color **1** **WHITE** Tape Option **3** **BT** **4** **SINGLE**
 (If Applicable)

2 **X105**
 Rubber Seal Profile

SINGLE **DUAL**

Single and Dual Option

Tape Options:
 NT = No Tape
 HT = General Acrylic PSA
 BT = 3M™ Bonded Tape System

"D" SECTIONS

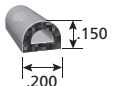
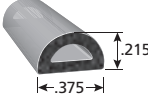
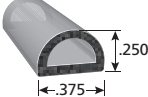
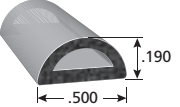
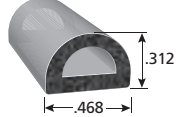
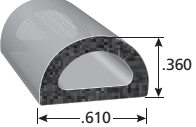
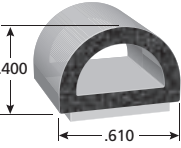
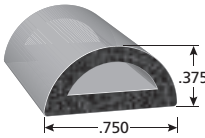
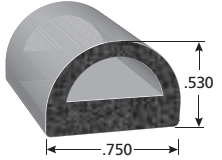
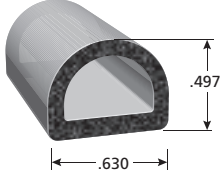
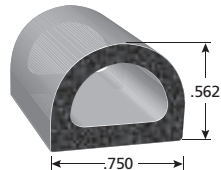
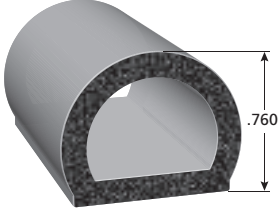
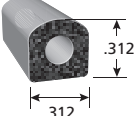
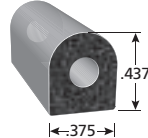
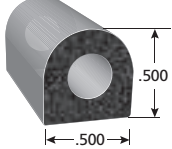
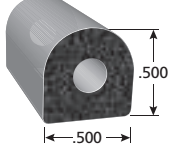
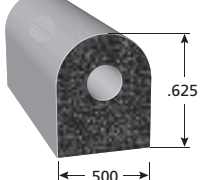
 X2476	 X1333	 X1153	 X1543	
 X110	 X109	 X2507	 X119	 X125
 X2373	 X135	 X1750	 X2576	
 X105	 X202	 X101	 X2338	

See page #42 for tape options

RUBBER SEAL

Part Number Example

Color **1** Tape Option **3** **4**

WHITE **X105 BT SINGLE** (If Applicable)

2 Rubber Seal Profile

Single and Dual Option

Tape Options:
 NT = No Tape
 HT = General Acrylic PSA
 BT = 3M™ Bonded Tape System

"D" SECTIONS

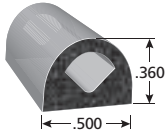

X108

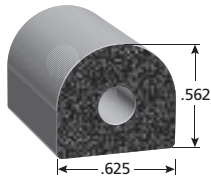

2012

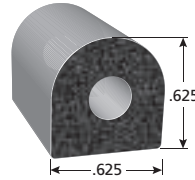

X5381

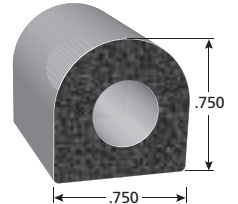

X1458

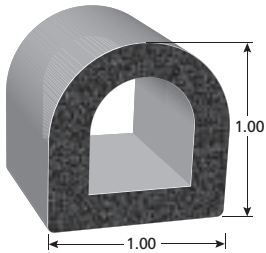

X5272

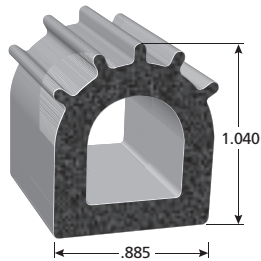

X2828

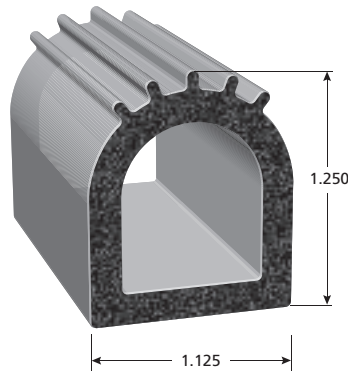

X2492

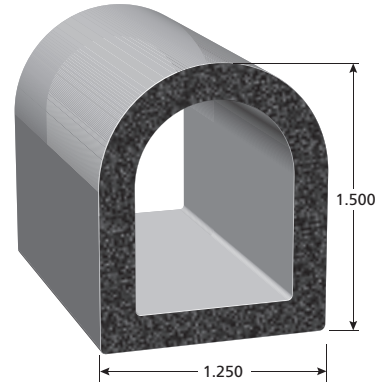

X1655

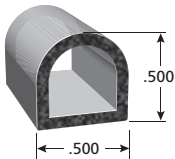

X1689

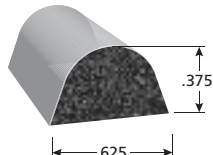

X2471

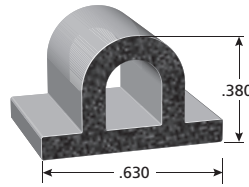

X1712

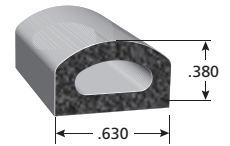

X1524

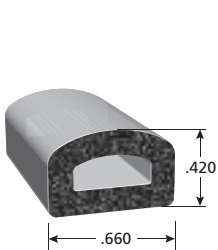

X2463

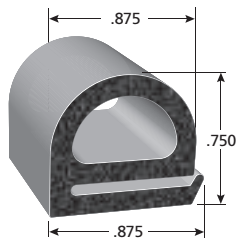

X1921

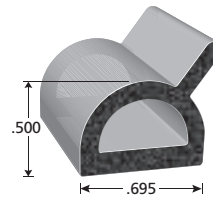

X5036

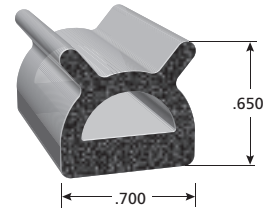

X2354

SEALS

RUBBER SEAL



SEALS

TRIANGLE SECTIONS

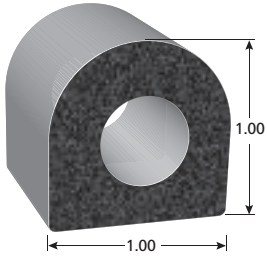

X1678

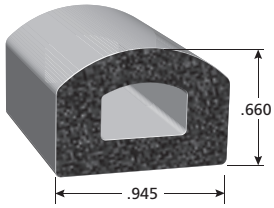

X1613

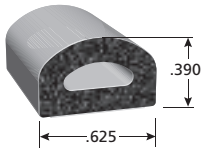

2495

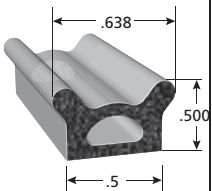

X2337

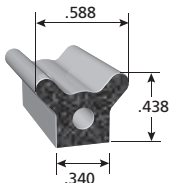

X2529

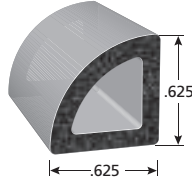

X2123

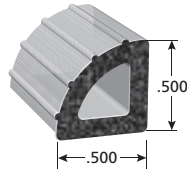

X2532

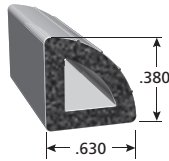

X2025

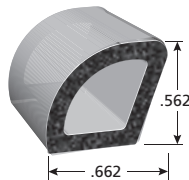

X1711

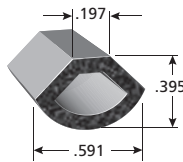

X1923

Adhesive Options – Choose the tape that fits your needs

“HT” GENERAL PURPOSE PRESSURE SENSITIVE ADHESIVE

This acrylic based adhesive is best used to hold the rubber seal in place while installed in a static application or compressed between two stationary objects. May be used in some light duty dynamic applications against a variety of substrates. Good heat performance -20F to +158F.

Please Note: During application ambient temperature must be above 60° F.



“BT” 3M™ HIGH STRENGTH TAPE SYSTEM

The ultimate bond between the rubber and substrate. Creates a moisture barrier and air tight seal between rubber and substrate. Highest peel and shear resistance, can be used under high loads of stress and force. Has low initial tack for easy re-positioning during installation and requires 72 hours of cure time for full bond strength. Good heat performance -20F to +158.

See page# 42 for tape options



See our how to install video at:
www.rubber-seal-install.info



PEDESTAL SEALS

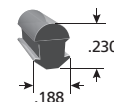

DD6109

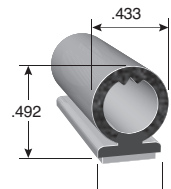

DD1604

RUBBER SEAL

"P" SEALS

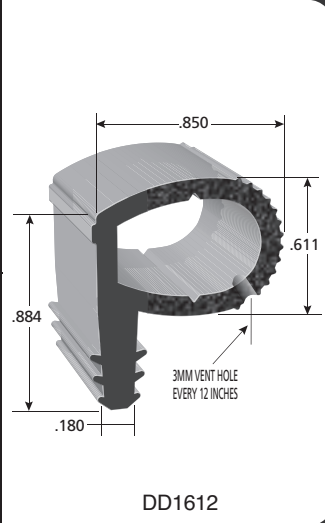
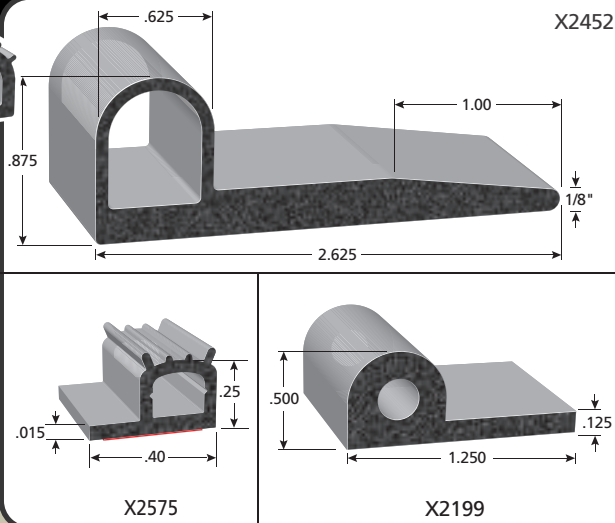

LID SEALS

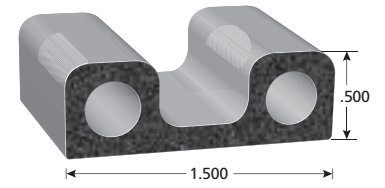

X402

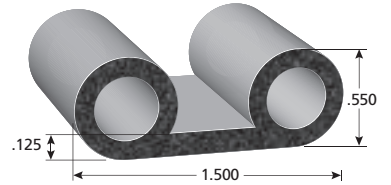

X1145

FENDER FLARE TRIMS

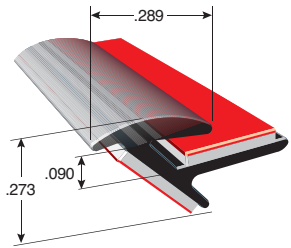

X1643BT
Roll size 500ft.
Dense



Actual size

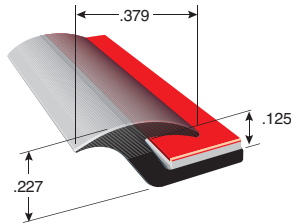

X1663BT
Roll size 500ft.
Dense



Actual size

Fender Flare Trim is a ozone resistant EPDM rubber that mounts between the flare and the body. **3M**™ automotive grade tape creates a solid bond between both surfaces.



Easily installed before fender flare is installed against body to isolate vibration and provide an attractive finish.



ADDITIONAL PROFILES

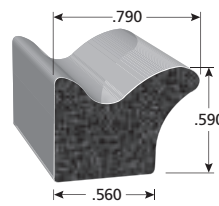

X1058

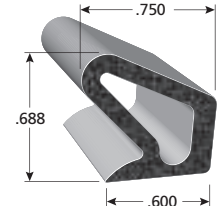

X1899

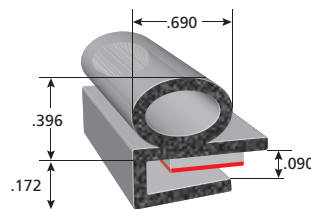

X2048

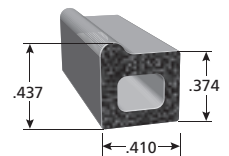

X2298

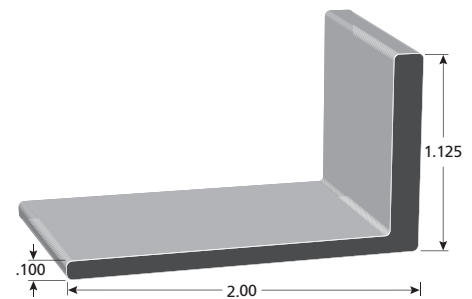

X2730

See page# 42 for tape options

RUBBER SEAL

Part Number Example

Color **1** **WHITE** Tape Option **3** **BT** **4** **SINGLE**
 (If Applicable)
Rubber Seal Profile

SINGLE **DUAL**
 Single and Dual Option

Tape Options:
 NT = No Tape
 HT = General Acrylic PSA
 BT = 3M™ Bonded Tape System

RIBBED SECTIONS

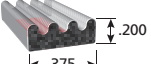
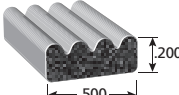
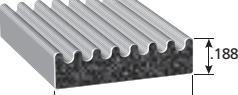
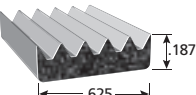
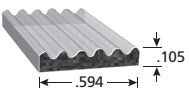
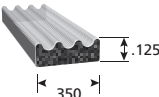
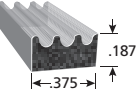
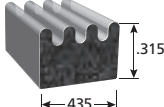
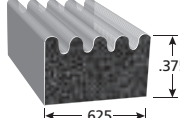
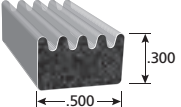
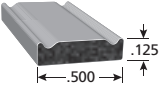
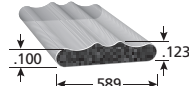
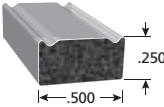
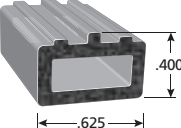
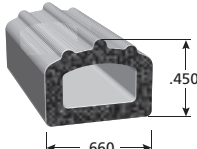
 X2421	 X2528	 X2220	 X1621	 X1568
 X2266	 X113	 X1698	 X103	 X2897
 X112	 X376	 X114	 X1705	 X2469

FLAP SECTIONS

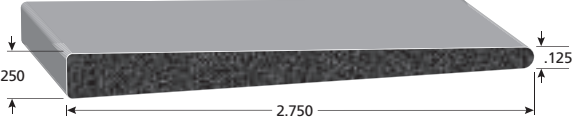
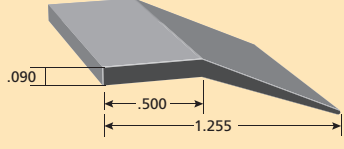
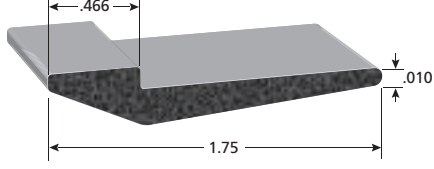
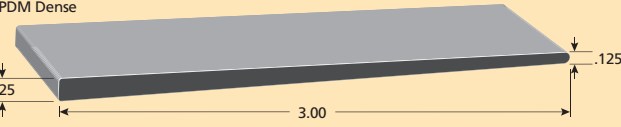
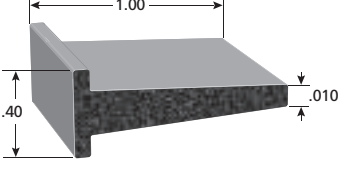
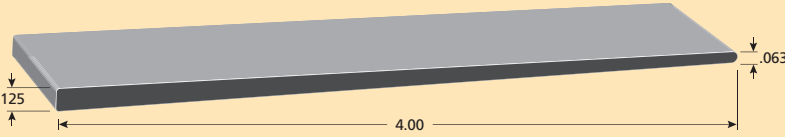
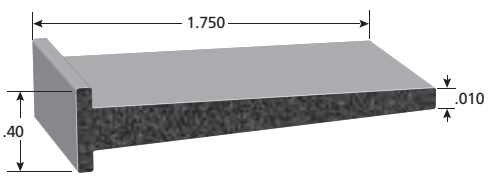
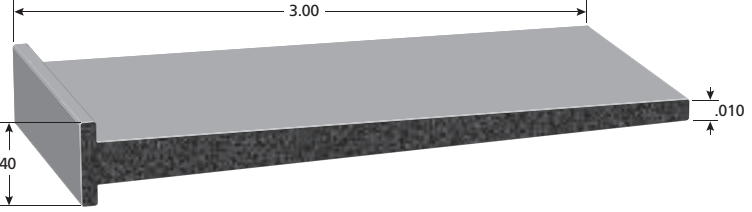
 X2877	 X2248 EPDM Dense
 8B	 X2045 EPDM Dense
 5B	 X2064 EPDM Dense
 6B	 7B



SEALS

RUBBER SEAL

CORNER GUARD

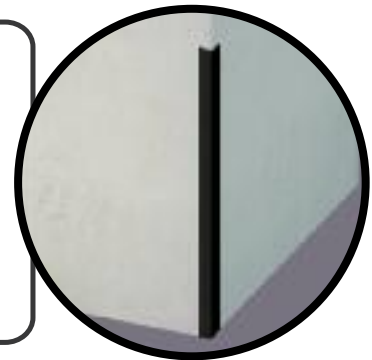
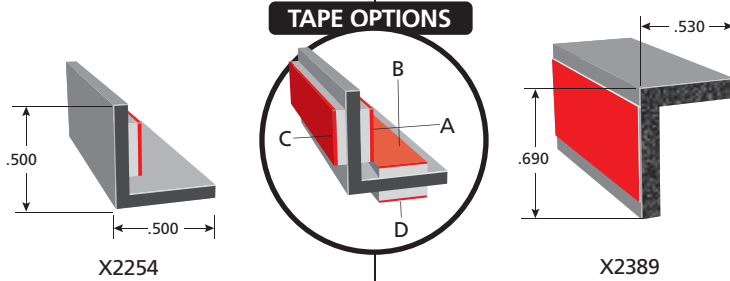

See page #42 for tape options

SPLICE CORD & WELTING

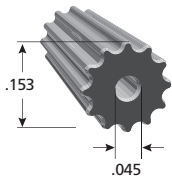

I11090

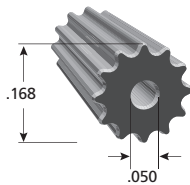

I11091

Profiles shown not to scale

TUBING AND CORD

SOLID ROUND

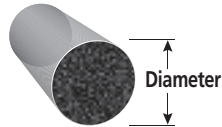

Part#	Diameter
X301	.25"
X303	.38"
X305	.50"
X307	.625"

TUBING

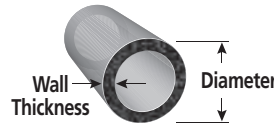

Part#	Diameter	Inside Dim.	Wall Thickness
X310	.236"	.174"	.031"
X311	.276"	.206"	.035"
X313	.38"	.028"	.050"
X315	.437"	.364"	.058"
X317	.63"	.474"	.078"
X319	.75"	.564"	.093"
*X321	1.0"	.075"	.125"

* These parts sold in 500 foot increments except X-321 (125ft)

SOLID RECTANGLE

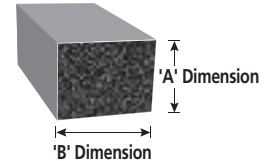

Part#	'A' Dim.	'B' Dim.
X272	.25"	.50"
X273	.38"	.50"
X274	.25"	.75"
X275	.50"	.75"
X1449	.75"	.375"
X1450	.75"	.125"
X268	.25"	.25"



FOR A WATER TIGHT SEAL!



Part Number Example

Color: **1** WHITE

Tape Option: **3** BT

Rubber Seal Profile: **2** X105

Single and Dual Option: **4** SINGLE

(If Applicable)

Tape Options:
 NT = No Tape
 HT = General Acrylic PSA
 BT = 3M™ Bonded Tape System

1-888-874-6565

TRIM-LOK INC.
www.trimlok.com

O-RINGS

O-Rings are manufactured out of EPDM medium density sponge rubber. They are manufactured with a "no-flash" joint that will comply to high tolerance requirements. Trim-lok's O-Rings can be manufactured to ANY length.

DESIGN-A-RING

Made to any length is easy as ABC

A	B	C
Outside Diameter	Required Length	Required Tolerance

Provide these dimensions and Trim-Lok can build the part you need.



SEALS

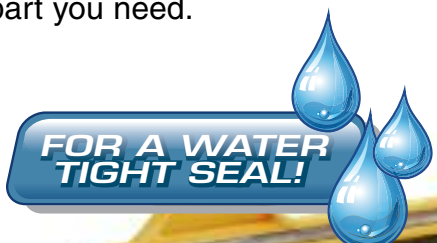

Part#	Cord Outside Diameter	Length
X2405-001	.275	34.125"
X2405-002	.275	39.0"
X2405-003	.275	42.0"
X2405-004	.275	56.75"
X2405-005	.275	62"
X2405-006	.275	108"
X2405-007	.275	69"
X2405-008	.275	110"
X2405-009	.275	94"
X2405-010	.275	96"
X2405-011	.275	52"
X2430-001	.150	15"
X2430-002	.150	18.1"
X2430-003	.150	18.3"
X2431-001	.325	104"
X2433-001	.220	57"
X2433-002	.220	53"
X2434-001	.250	50"
X2434-002	.250	61.25"
X2434-003	.250	98"
X2434-004	.250	123"
X2434-005	.250	67.25"
X2435-001	.265	76.75"
X2436-001	.295	100"

LOCKING GASKET

Locking Key (Part 2)

One-Piece Locking Gasket

Two-Piece Locking Gasket (Part 1)

Dense EPDM Rubber

Plastic Installation Tool
Item #365-0004

Locking Gasket is an EPDM dense rubber extrusion designed to lock in the installation of stationary windows or windshields. Locking Gaskets provide a secure seal between a metal or fiberglass body panel and a glass or plexiglas window. Available in one-piece and two-piece styles with a lock-strip, and are highly resistant to numerous environmental conditions.

- Resistance to Ozone — Excellent
- Water Absorption — Excellent
- Sunlight Aging — Excellent
- Low Temperature — Excellent
- General Temperature Rating -40° to + 212°

ONE-PIECE LOCKING GASKETS

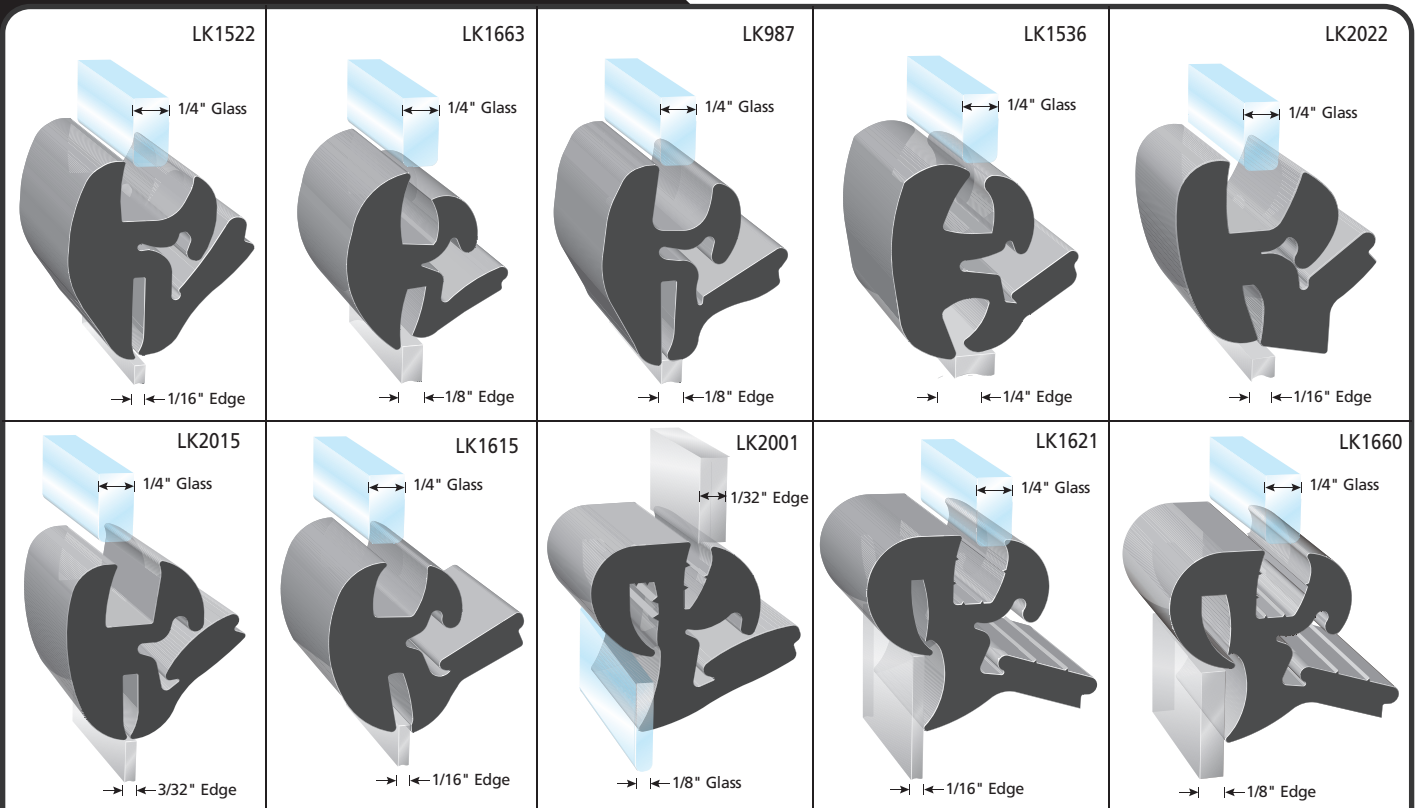

	Part Number	Glass Panel Thickness	Body panel thickness	**Minimum recommended clearance between glass and edge	Overall Height	Minimum recommended radius of panel opening	Weight per foot
<p>** Minimum Recommended Clearance</p>	LK1522	0.1875" - .250"	0.035" - 0.067"	0.301"	1.07"	2.50"	0.275 lbs.
	LK1663	0.1875" - .250"	0.09" - 0.14"	0.220"	0.90"	1.50"	0.196 lbs.
	LK987	0.1875" - .250"	0.09" - 0.14"	0.265"	1.07"	2.50"	0.246 lbs.
	LK1536	0.1875" - .250"	0.1875" - 0.25"	0.406"	1.09"	3.50"	0.225 lbs.
	LK2022	0.250" - .313"	0.04" - .08"	0.280"	0.970"	2.50"	0.323 lbs.
	LK2015	0.200" - .250"	0.075" - .095"	0.260"	0.95"	2.50"	0.236 lbs.
	LK1615	0.1875" - .250"	0.06" - 0.09"	0.300"	0.906"	2.50"	0.275 lbs.
	LK2001	0.120" - .140"	0.030" - .060"	*.160"	1.00"	2.50"	0.286 lbs.
	LK1621	0.1875" - 0.250"	0.046" - 0.075"	*.140"	0.937"	2.00"	0.26 lbs.
	LK1660	0.1875" - 0.250"	0.075" - 0.140"	*.140"	1.00"	2.00"	0.293 lbs.

* Offset dimension between glass and body panel.

LOCKING GASKET

INSTALLATION



1. Secure Locking Gasket to body panel.



2. Lubricate Locking Gasket. Then slide glass in bottom first.



3. Finish working rubber around glass with tools found on pages 40-41.



SEALS

TWO-PIECE LOCKING GASKETS

Part 1

See our how to install video at: www.locking-gasket-install.info



LK1035

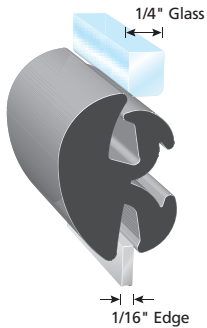

LK1179



LK1488



LK1456



LK1696



Part 2 LOCKING KEY OPTION

Installed Profile Example

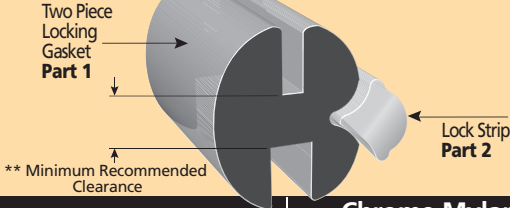

Black Insert Key

Chrome Mylar Strip Insert Key

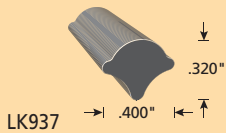

LK937

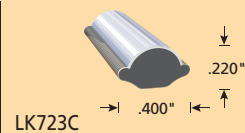

LK723C

LK1573

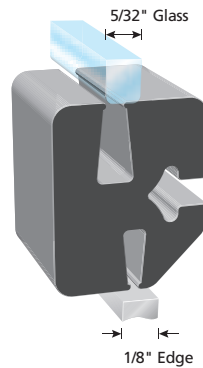

LK2016



LK2004

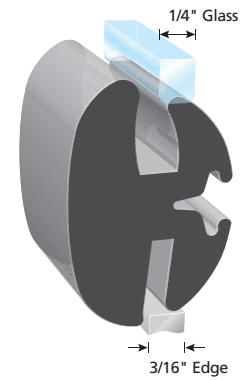

Part Number	Glass Panel Thickness	Body panel thickness	**Minimum recommended clearance between glass and edge	Overall Height	Minimum recommended radius of panel opening	Weight per foot	Matching insert key part number (part 2)
LK1035	0.1875" - .250"	0.050" - .095"	0.23"	0.85"	2.25"	0.155 lbs.	LK937
LK1179	0.1875" - .250"	0.093" - .140"	0.30"	1.10"	2.5"	0.277 lbs.	LK937
LK1488	0.1875" - .250"	0.1875" - .250"	0.30"	1.00"	3.5"	0.202 lbs.	LK937
LK1456	0.1875" - .250"	0.175" - .188"	0.30"	0.95"	2.0"	0.198 lbs.	LK937
LK1696	0.1375" - .250"	0.175" - .188"	0.260"	0.95"	2.0"	0.193 lbs.	LK937
LK1573	0.125" - .187"	0.100" - .140"	0.246"	0.961"	4.0"	0.289 lbs.	LK937
LK2016	0.180" - .220"	0.100" - .130"	0.265"	1.29"	4.0"	0.358 lbs.	LK937
LK2004	0.180" - .220"	0.09" - .125"	0.35"	1.07"	2.5"	0.241 lbs.	LK937



See page 40-41 for more information on Locking Gasket installation tools.

TOOLS AND ACCESSORIES

(A) Instant Adhesive

A superior adhesive bond on "hard to glue" surfaces that creates a secure seal on corners and joints. It protects TRIM-LOK products against harsh conditions by bonding ends securely. This product bonds rubber, plastic, fiberglass, metal, wood, paper, leather, and foam. It cures in 0 - .25 seconds with a temperature range of 20°F to +150°F, with full cure in 24 hours.

1.2 oz (34g a bottle)
STOCK #4401TL

(B) Straight Edge Clipper

A compact hand-held tool that creates a professional appearance on most applications. Product comes with 2 replacement blades (2 blades/pkg.)

STOCK #WCSC1
Replacement Blades #RBA

(C) EC-1 Tool

General purpose cutter.
STOCK #EC-1

(D) Handheld Roller

A handheld roller to assist with the correct application pressure needed for all Rubber Seal adhesives.

STOCK #HR-1

(E) Ball End for 1-piece Locking Gasket

This tool has a small, round steel ball on the end. Once the steel ball is inserted down into the rubber gasket, it is very difficult for it to come out. If it should slip out of the gasket, there is less of a chance you will scratch the paint of the vehicle you are working on.

STOCK #365-0007

(F) Lock Strip Insertion

Features off-set handle to keep hands away from glass and two double end tips that will fit most applications. The unique design allows the tip to swivel 90 Degrees.

STOCK #365-0008



ACCESSORIES



(G) Rubber Seal 90° Miter Tool

Heavy-duty construction provides clean, 90° miter cuts with minimal effort and perfect for creating corners and Rubber-Seals.

STOCK# GS849RS

(H) 90° Miter Tool

A perfect miter with the close of your hand! This tool is designed to miter, notch or trim a variety of materials, including metals, plastics, and mitering metal core trim.

STOCK #GSS851

Blade Replacement #GS850

(I) Locking Gasket Tool

Specifically designed to ensure a safe, easy and efficient installation of Locking Gaskets for stationary windows and other glass application.

STOCK #365-0000

(J) Pneumatic Hammer

This palm size pneumatic hammer applies trims and seals where speed and high volume installations are essential. This product eliminates the need for a variety of cumbersome hammers and mallets.

STOCK #AH-1

(K) Gasket Rope Insert

This handy gasket rope insert tool is designed to ease the rope under the lip and seat it in the groove of the gasket. It Comes with a sturdy 20 foot rope.

STOCK #365-0005

(L) Pigtail for 1-piece Locking Gasket

It can be difficult to fold the self-locking rubber into the locking part. This tool solves this problem by rolling the locking lip into the body easily.

STOCK #365-0006



Utilizing the right material

EPDM (Ethylene-Propylene-Diene-Monomer) is well known for its excellent ozone, weathering and aging resistance. It also has excellent water and steam resistance, maintains its flexibility at low temperatures, features excellent resistance to alkalis, acids and oxygenated solvents, and is very color stable. It is not recommended for resistance to oil, gasoline and hydrocarbon solvents. EPDM is found in a wide range of applications and is excellent for outdoor use.

Neoprene (Polychloroprene) has moderate resistance to oils and gasoline. It features good flame resistance, weathers well and has very good resistance to abrasion, flex cracking, alkalis and acids. However, expect poor resistance to aromatic and oxygenated solvents and limited flexibility at low temperatures. Neoprene is generally considered an excellent all-purpose elastomer with a solid balance of properties and few limitations.

Nitrile (Acrylonitrile-butadiene) has very good oil and abrasion resistance to alkalis and acids increases as the nitrile content of the compound increases. Nitrile must be specially compounded for resistance to ozone, sunlight and natural aging. It has poor resistance to oxygenated solvents. Nitrile is superior to neoprene in oil and solvent resistance, but is not recommended for applications where it is exposed to severe weathering.

Nitrile PVC provides premium performance and long-term reliability in very harsh and corrosive environments. Has exceptional resistance to heat aging and a broad range of fuels, solvents and chemicals makes it ideal for many demanding aerospace, automotive and industrial applications. Fluoroelastomers also offer excellent resistance to weather, ozone, oxygen and sunlight, and are inherently more flame retardant than hydrocarbon rubbers. Fluoroelastomers have poor resistance to ketones, ester, ethers, amines and aqueous bases (e.g., ammonia and sodium hydroxide).

TPE (Thermoplastic Elastomers) are materials that have the properties and performance of rubber but are processed like thermoplastics. Performance properties are similar to conventional thermosets such as EPDM or neoprene. TPE has good direct flame resistance as well as aliphatic and aromatic hydrocarbon solvents, oil and gasoline.

PVC has excellent impact strength, good resilience, tensile strength, abrasion resistance and maintains flexibility at lower temperatures. It is not the polymer of choice when resistance to oil, gasoline and hydrocarbon solvents is required.

Choosing the right adhesive

ADHESIVE OPTIONS

BT 3M™ BONDED TAPE SYSTEM

The ultimate bond to the rubber and the ultimate bond to the substrate. Specifically designed to perform in dynamic applications, this engineered tape system creates a moisture barrier and air tight seal between rubber and substrate. Highest peel and shear resistance, low initial tack for easy repositioning during installation and needs 72 hours of cure time to come to full bond strength. Good heat performance -20F to +158F.

ADHESIVE CROSS SECTION

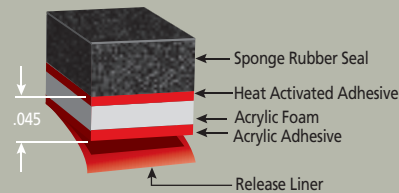

HT STANDARD PRESSURE SENSITIVE ADHESIVE

This acrylic based adhesive is best when used to hold the rubber seal in place in a static application or compressed between two stationary objects. May be used in some light duty dynamic applications against a variety of substrates. Good heat performance -20F to +158F.

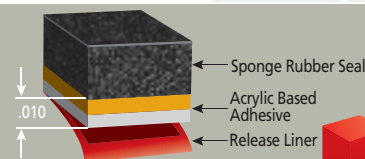

HTR HIGH TACK PRESSURE SENSITIVE ADHESIVE

This rubber based adhesive is best when used to hold the rubber seal in place while installing in static applications or compressed between two stationary objects. HTR has better initial tack as well as adhering to some difficult bond surfaces such as polypropylene and polyethylene. Heat limitations -20F to +130F.

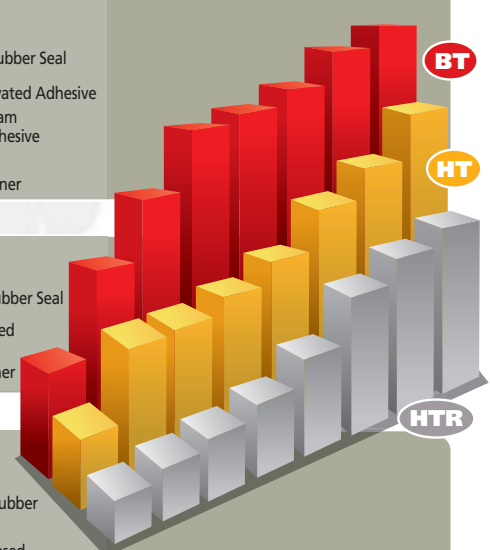
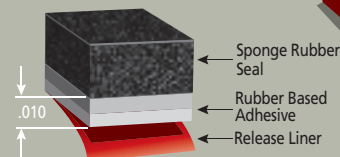

CLEANING AND APPLICATION INSTRUCTIONS

Regardless of what bonding surface you apply the gasket to it must be clean and free of surface contaminants such as oils, greases, mold releases and dirt in general. Most bonding failures are not due to the adhesive failing but instead the failure to properly clean the surfaces. Prior to applying any of these adhesives clean surface with 50% denatured alcohol and 50% water solution.

Trim-lok's Quality is First!

Customer satisfaction is our number one priority. Our objective is to ship quality and reliable products to all of our valued customers. Our goal is to maintain a Quality Management System that meets or exceeds the requirements of ISO/TS 16949 and ISO 9001.

Trim-lok's Service

Trim-lok's Mission is: "To be the leader and trusted supplier of choice for innovative Trim and Seal solutions". With over 40 years of consistent growth Trim-Lok has proven to its' customers that premier customer service and quality is the priority. Trim-Lok has provided support to their customers by shipping on time for both off-the-shelf and custom extruded parts.

Trim-Lok Custom Fabricated Solutions

Trim-Lok brings the most experienced team in the industry toward the development of custom fabricated solutions across all of the industries it serves. Trim-lok's product development assistance unifies industrial design, engineering rigid prototyping and manufacturing to serve their customers. Trim-lok's product development team brings high caliber mechanical design, excellent materials knowledge, and strong manufacturing expertise. All of our processes involve continuous improvement and our employees are recognized for their contributions to this end. All aspects of Trim-Lok from custom design to engineered solutions to on-time deliveries are centered around Keeping the Customers Satisfied and our highest priority.

Trim-lok's CAPABILITIES & DELIVERABLES

MATERIALS

Rubber

- (EPDM) Ethylene-Propylene-Diene-Monomer-Sponge and dense in various durometers
- (NBR/PVC)Acrylonitrile Butadiene, Nitrile, PVC
- (CR)Chloroprene, Neoprene
- (SI) Silicone

Plastic

- TPE, TPO, TPU, TPV, TPR
- Flame resistant PVC
- PVC (Flexible and Rigid)
- (HDPE, LDPE, LLDPE) Polyethylene
- (ABS) Acrylonitrile-Butadiene-Styrene
- Polypropylene

- Single, and Co-Extrusions
- High Tolerance Splicing
- Plastic Welding
- Pressure Sensitive Adhesives
- Continuous or Cut to Length
- Custom Design/Profile
- Custom Kit Assemblies
- Private Label Packaging
- Custom Color Matching
- Notching
- In-line Printing
- Mitered Corners and Frame Assemblies
- Hot Bonded Corners
- Cold Bonded Corners
- Injection Molded Corners
- Film Splicing
- Drilling / Punching
- Decorative Mylar Application
- Slip Coating





TRIM-LOK, INCORPORATED LIMITED WARRANTY

Trim-Lok® Inc. warrants all applicable products to be free from defects in material and workmanship for a period of ninety (90) days from date of purchase. This warranty does not include damage to products resulting from accident, misuse, improper installation or storage, and unauthorized alterations.

Trim-Lok's warranty obligation shall be limited to furnishing substitute products for original products, which in Trim-Lok's sole judgement, have proven defective in material or workmanship within the ninety (90) day warranty period.

Any implied warranties of merchantability or propriety for any particular purpose, shall be strictly limited in duration to that of the express warranty set forth above. In no event shall Trim-Lok be liable for any special, incidental or consequential damages resulting from the manufacture, sale, or use of these products under any legal theory. Said damages shall include, but not be limited to, lost profits, damage to property, or damages for personal injury. Trim-Lok's liability shall in no case exceed the price paid for the product claimed to be defective.

RETURNS:

Trim-Lok will not accept returns without prior authorization of a RMA number issued and marked on the return merchandise. Returns may be subject to shipping and restocking charges. Trim-Lok reserves the right to ship and bill up to 10% over and under quantity ordered on all parts.

NOTE:

Some ingredients used in these products, or their component materials, may not be compatible with certain surfaces. These ingredients may cause staining and or other consequential damages.

CATALOG INFORMATION:

The information contained in this catalog is based upon data believed to be accurate. Specifications and products are based upon information at the time of printing and are subject to change without notice and without incurring liability. No guarantee or warranty is made of the catalogs accuracy. Trim-Lok assumes no liability for product failure unless specifically stated in writing by an authorized representative of Trim-Lok. No warranties, expressed or implied, other than Trim-Lok's written limited warranty, will be honored.



6855 Hermosa Circle • Buena Park, CA • 90622-6180

Toll Free: 1-888-TRIM-LOK (874-6565)

(714) 562-0500 • FAX: (714) 562-0600 • E-Mail: info@trimlok.com • Website: www.trimlok.com

©2011 Trim-Lok, Inc. All rights reserved.